



US007225895B2

(12) **United States Patent**
Sahyoun

(10) **Patent No.:** **US 7,225,895 B2**

(45) **Date of Patent:** ***Jun. 5, 2007**

(54) **AUDIO SPEAKER WITH WOBBLE FREE VOICE COIL MOVEMENT**

(76) Inventor: **Joseph Yaacoub Sahyoun**, 3031 Hopkins Ave., Redwood City, CA (US) 94062

(*) Notice: Subject to any disclaimer, the term of this patent is extended or adjusted under 35 U.S.C. 154(b) by 212 days.

This patent is subject to a terminal disclaimer.

(21) Appl. No.: **10/753,278**

(22) Filed: **Jan. 8, 2004**

(65) **Prior Publication Data**

US 2004/0188174 A1 Sep. 30, 2004

Related U.S. Application Data

(63) Continuation-in-part of application No. 10/058,868, filed on Jan. 28, 2002, now Pat. No. 6,675,931, which is a continuation-in-part of application No. 09/542,155, filed on Apr. 4, 2000, now Pat. No. 6,460,651, which is a continuation-in-part of application No. 09/201,398, filed on Nov. 30, 1998, now Pat. No. 6,044,925.

(51) **Int. Cl.**

- H04R 7/12** (2006.01)
- H04R 7/22** (2006.01)
- H04R 9/04** (2006.01)
- H04R 9/06** (2006.01)
- G10K 13/00** (2006.01)
- H04R 9/02** (2006.01)

(52) **U.S. Cl.** **181/157; 181/163; 181/171; 181/172; 181/147; 381/335; 381/398**

(58) **Field of Classification Search** 181/157, 181/161, 163, 165, 171, 172, 147, 164, 162; 381/335, 398

See application file for complete search history.

(56) **References Cited**

U.S. PATENT DOCUMENTS

- 2,231,479 A * 2/1941 Perry 381/186
- 2,234,007 A * 3/1941 Olson et al. 181/172
- 2,269,284 A * 1/1942 Olson 381/342
- 3,684,052 A * 8/1972 Sotome 381/398
- 4,207,963 A 6/1980 Klasco 181/147
- 4,228,327 A * 10/1980 Sawafuji 381/398
- 4,477,699 A * 10/1984 Wada et al. 381/184

(Continued)

FOREIGN PATENT DOCUMENTS

- DE 30 20 146 12/1981
- DE 39 23 189 1/1991
- WO WO 97/46047 12/1997

Primary Examiner—Edgardo San Martin

(74) *Attorney, Agent, or Firm*—Allston L. Jones

(57) **ABSTRACT**

A speaker that is designed to substantially eliminate wobble of the voice coil during operation, and thus remove that source of distortion and early failure of the speaker. This is accomplished with the creation of triangular ring that extends upward from the top edge of the voice coil bobbin with that ring mating with a flat diaphragm at a right angle directly above the top edge of the bobbin. The outer edge of the diaphragm connects to the inner edge of the surround at the point where a sloping side of the “triangle” is also connected and slopes down to the top edge of the bobbin where the opposite end is connected. The outer portion of the diaphragm provides the third side of the triangle.

14 Claims, 40 Drawing Sheets

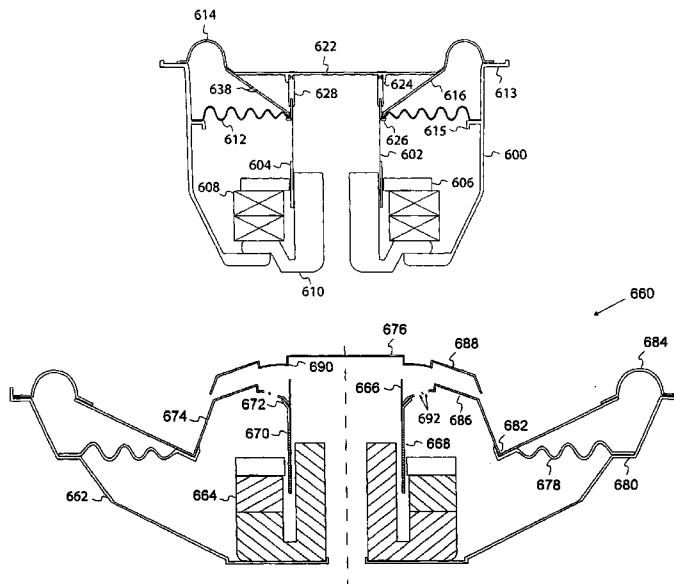

US 7,225,895 B2

Page 2

U.S. PATENT DOCUMENTS

4,517,416	A *	5/1985	Goossens	381/431	6,445,803	B1 *	9/2002	Boon et al.	381/184
4,567,327	A *	1/1986	Goossens et al.	381/185	6,496,590	B2 *	12/2002	Proni	381/423
5,143,169	A *	9/1992	Ziegenberg et al.	181/144	6,658,129	B2 *	12/2003	D'Hoogh	381/349
5,748,759	A *	5/1998	Croft et al.	381/398	6,672,423	B2 *	1/2004	Kato	181/161
5,883,967	A *	3/1999	House	381/398	2005/0078849	A1 *	4/2005	Funahashi et al.	381/412
5,933,512	A *	8/1999	Tamura	381/424	2006/0274914	A1 *	12/2006	Horigome et al.	381/424
6,160,898	A *	12/2000	Bachmann et al.	381/425	2006/0285718	A1 *	12/2006	Funahashi	381/403
6,259,800	B1 *	7/2001	Tagami	381/412					

* cited by examiner

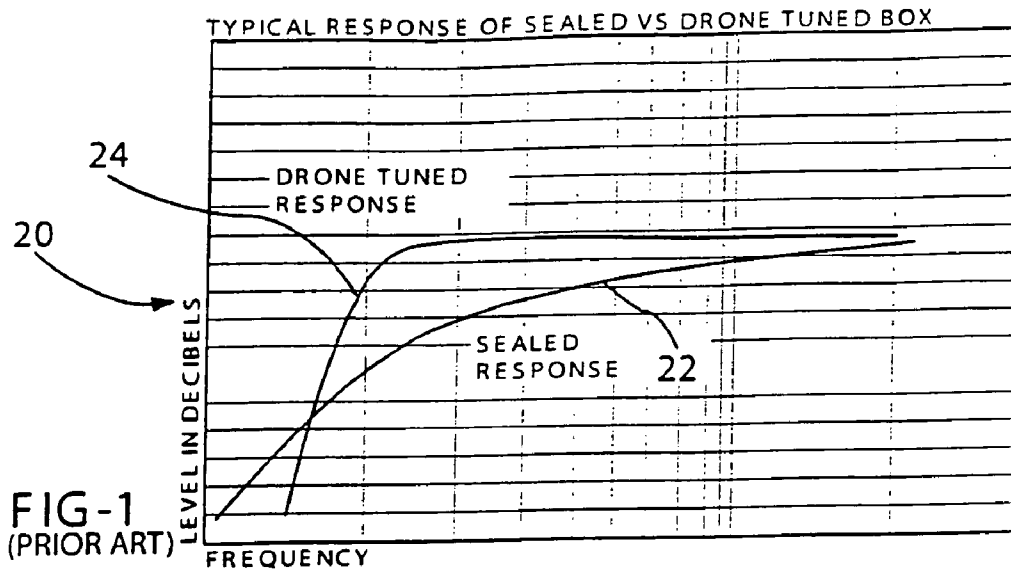

FIG-1
(PRIOR ART)

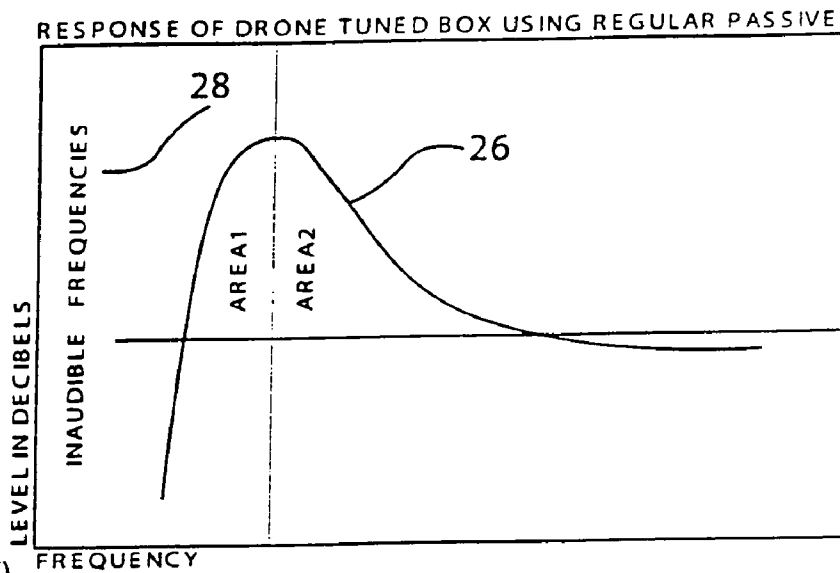

FIG-2
(PRIOR ART)

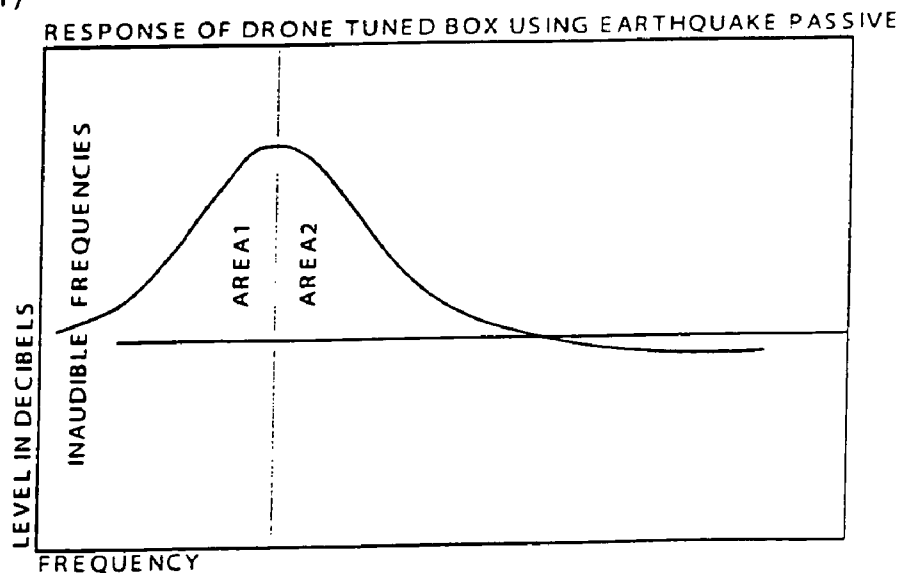
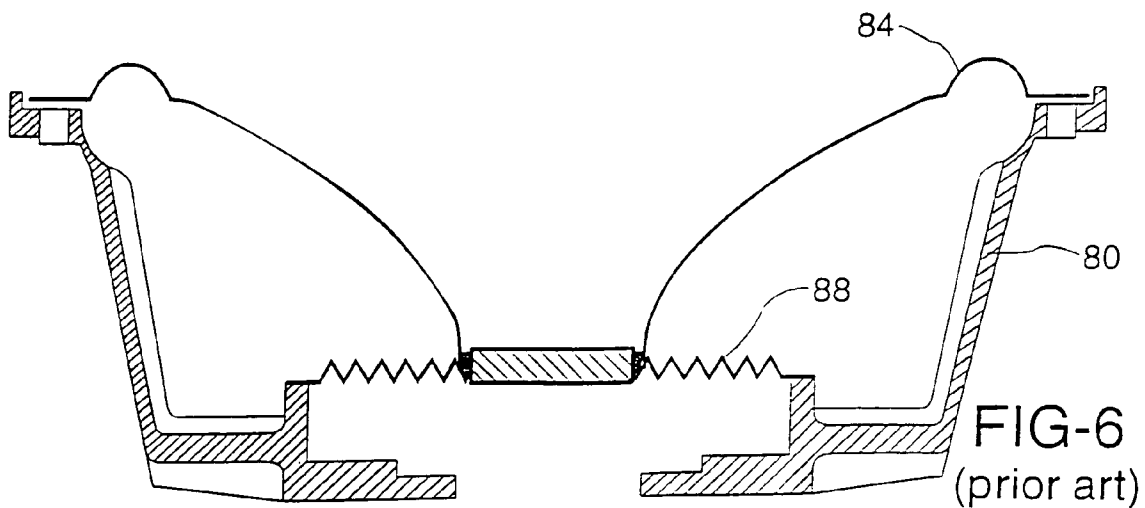
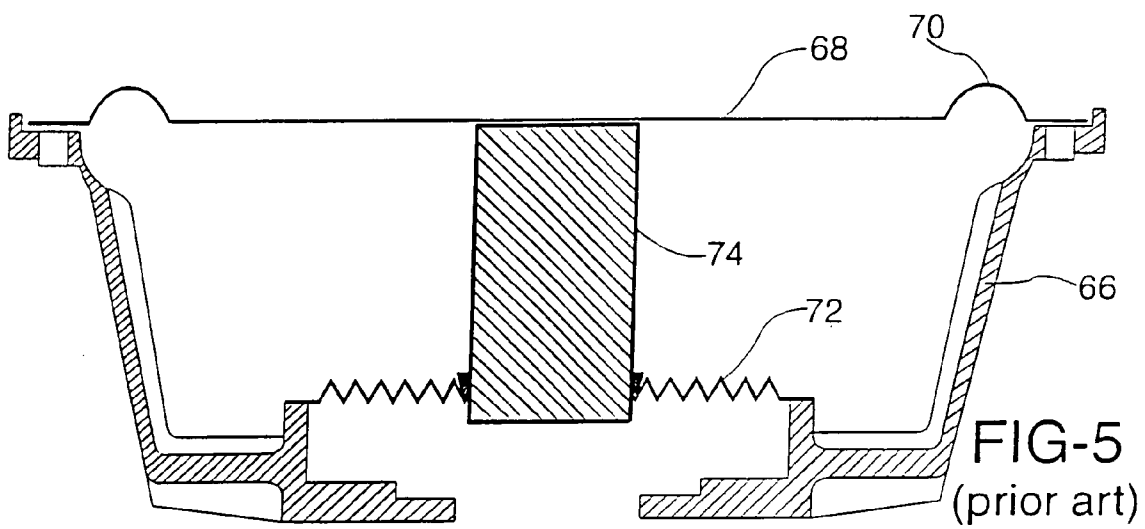
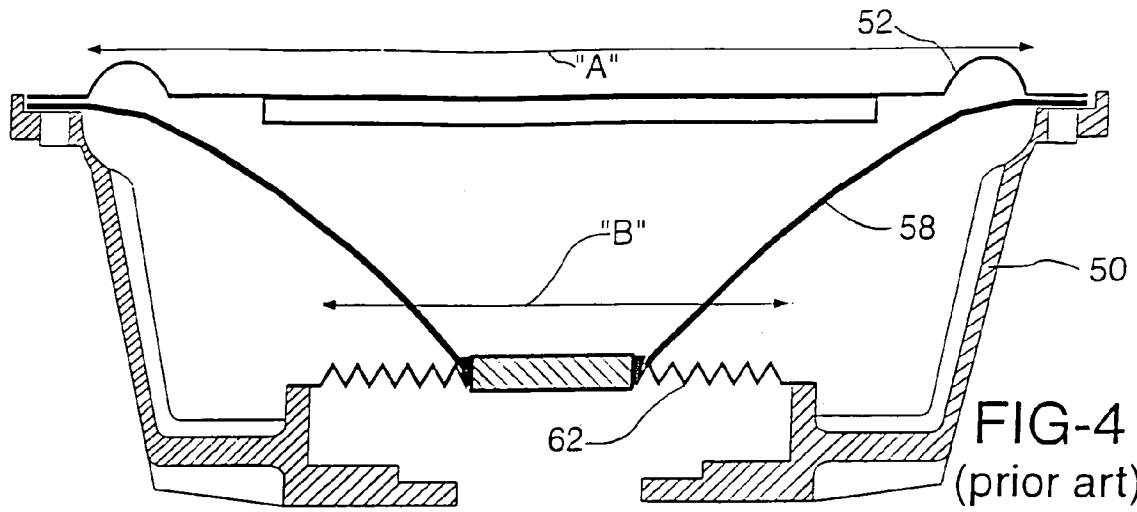

FIG-3



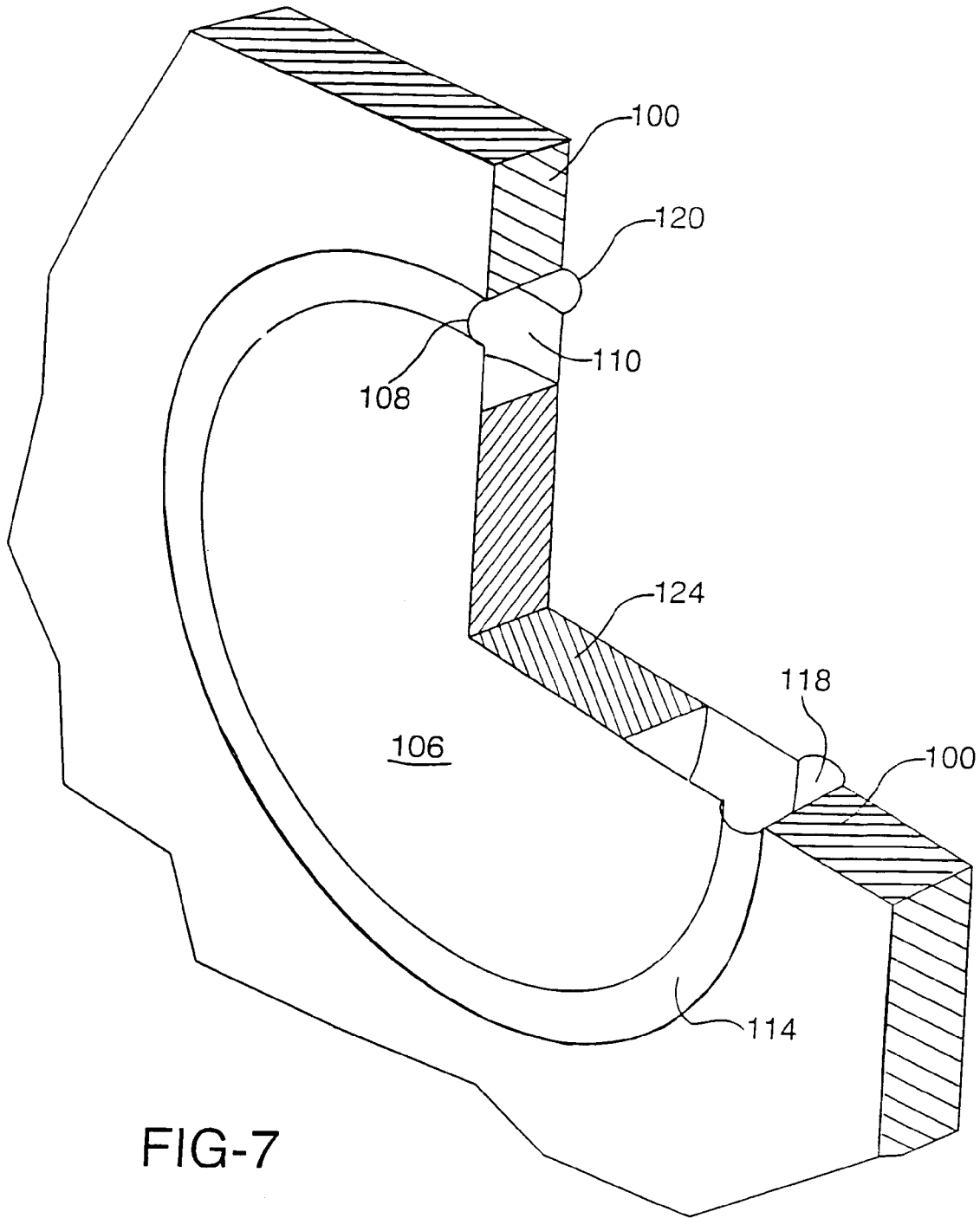
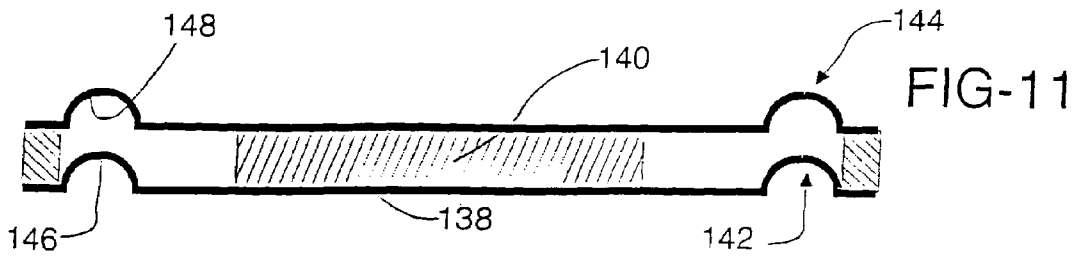
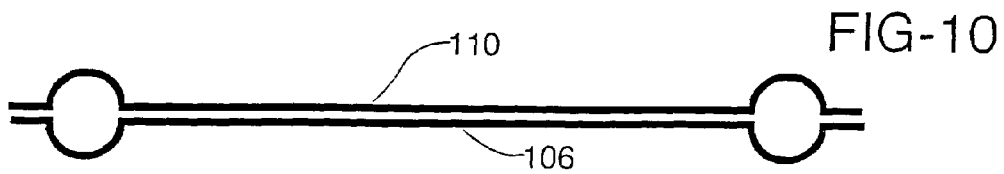
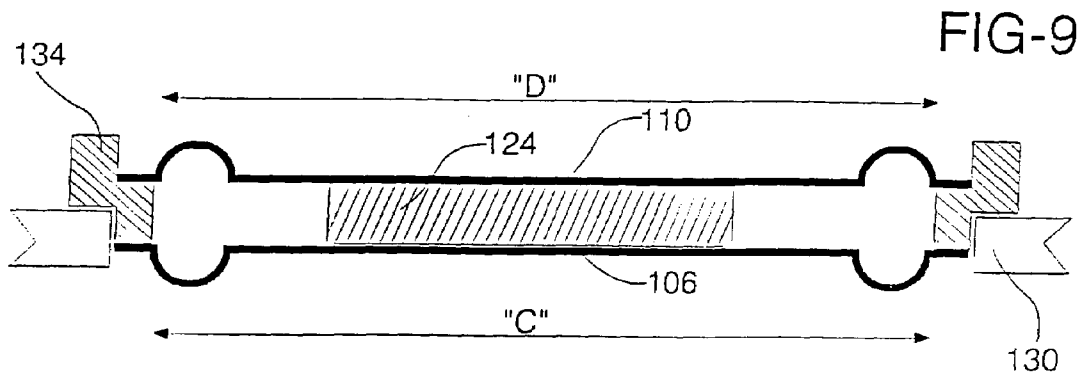
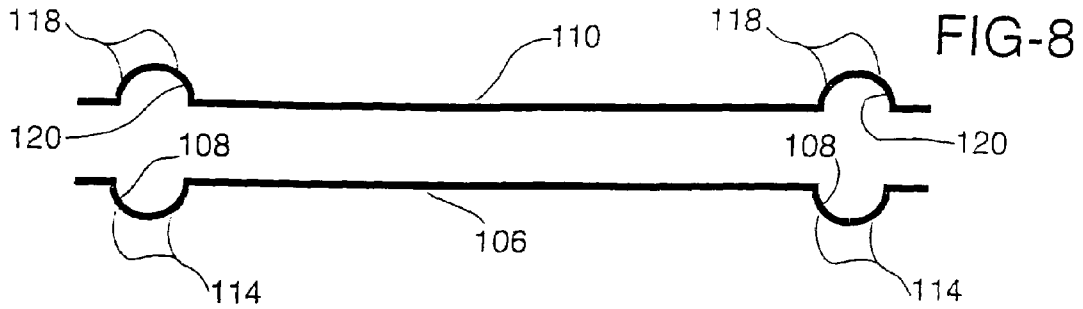
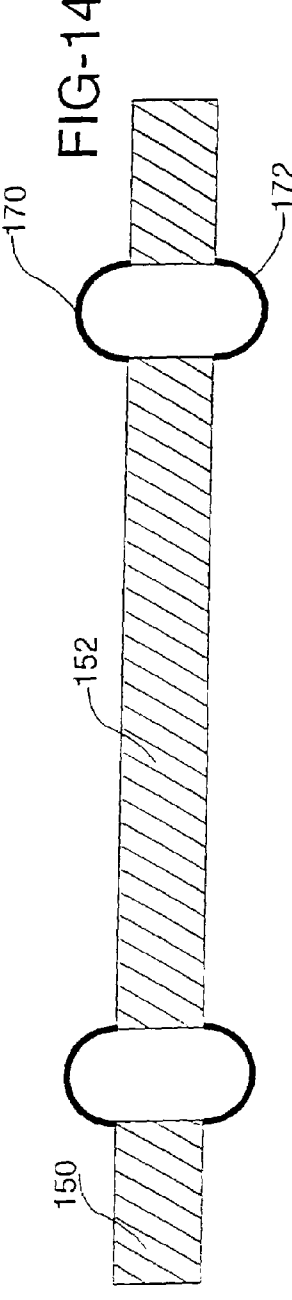
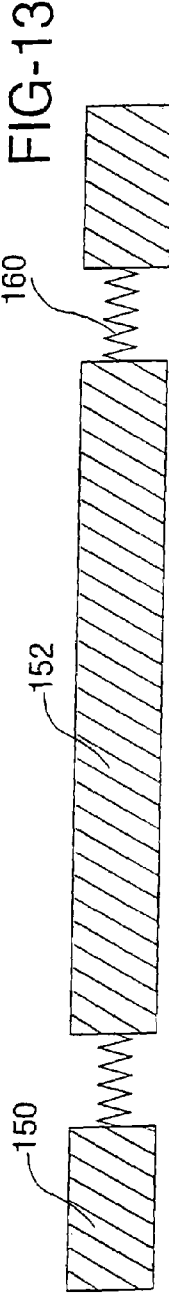
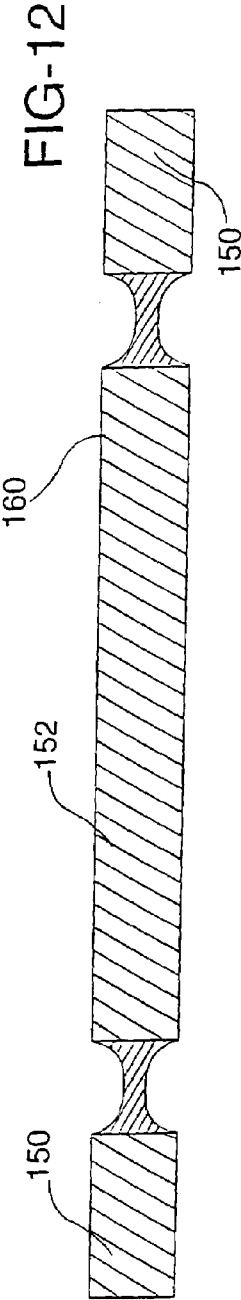
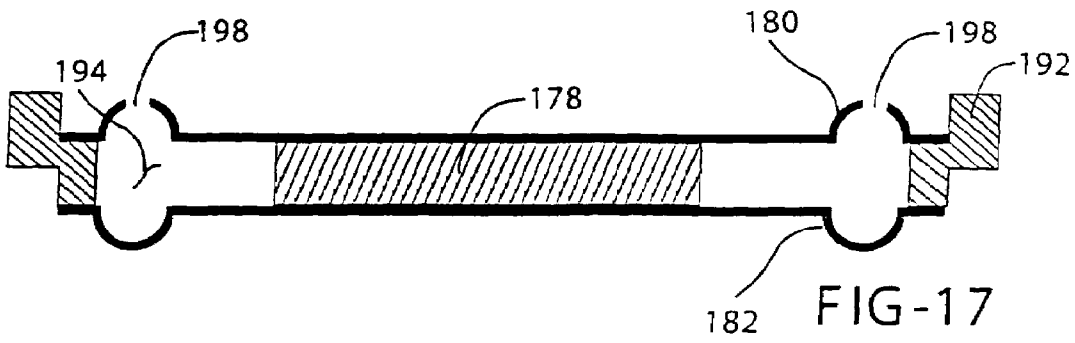
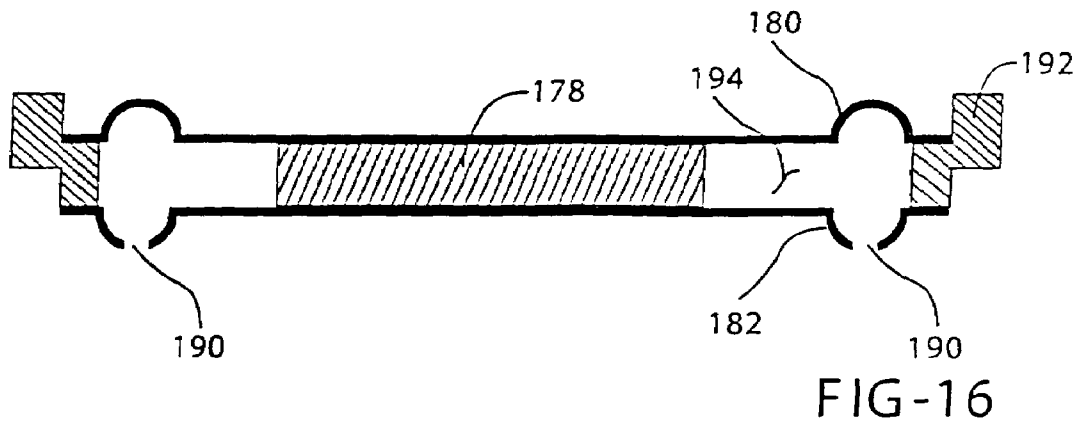
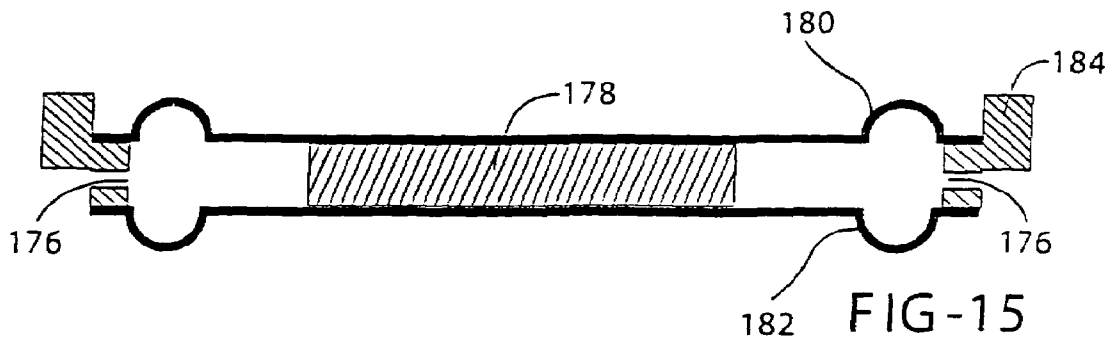

FIG-7







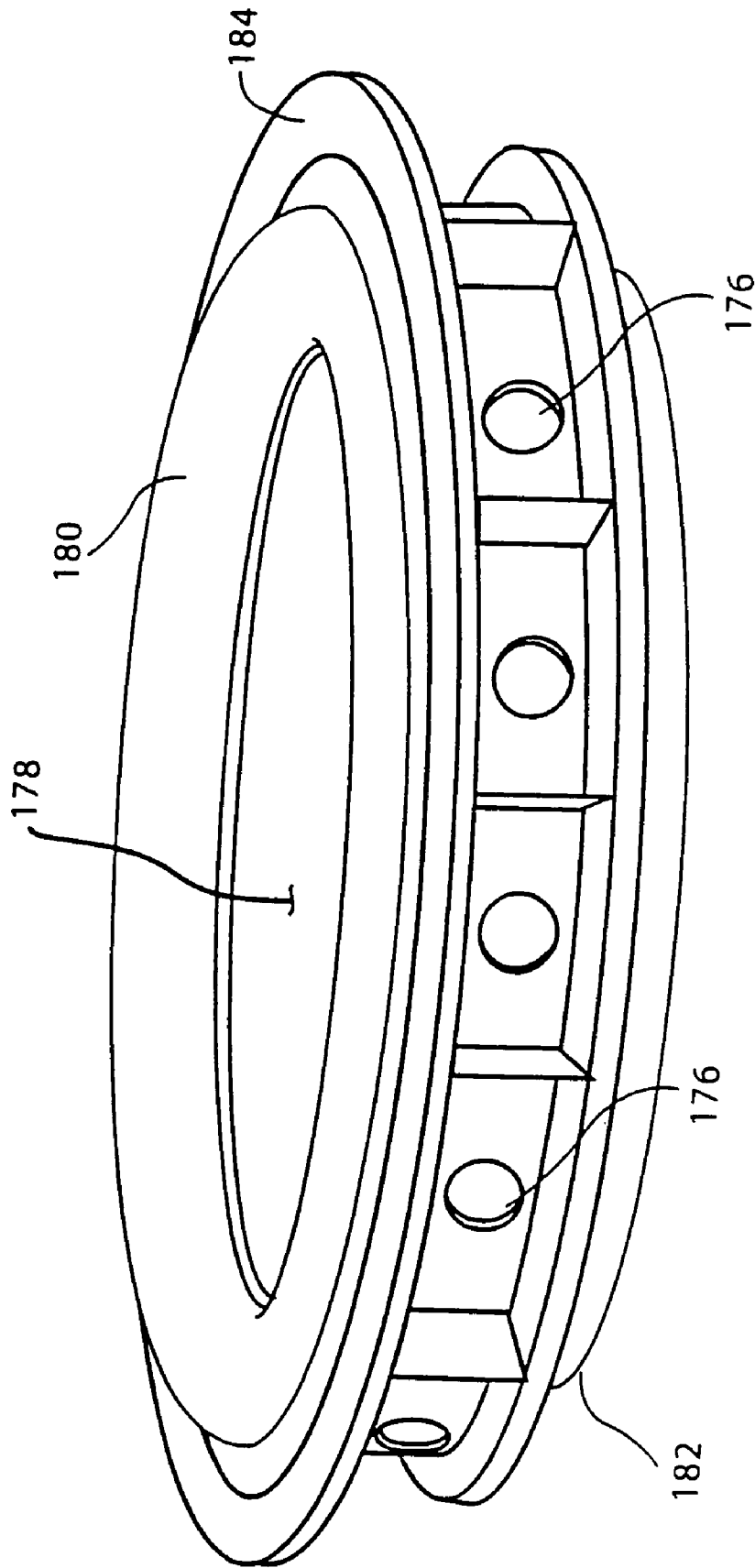

FIG-18

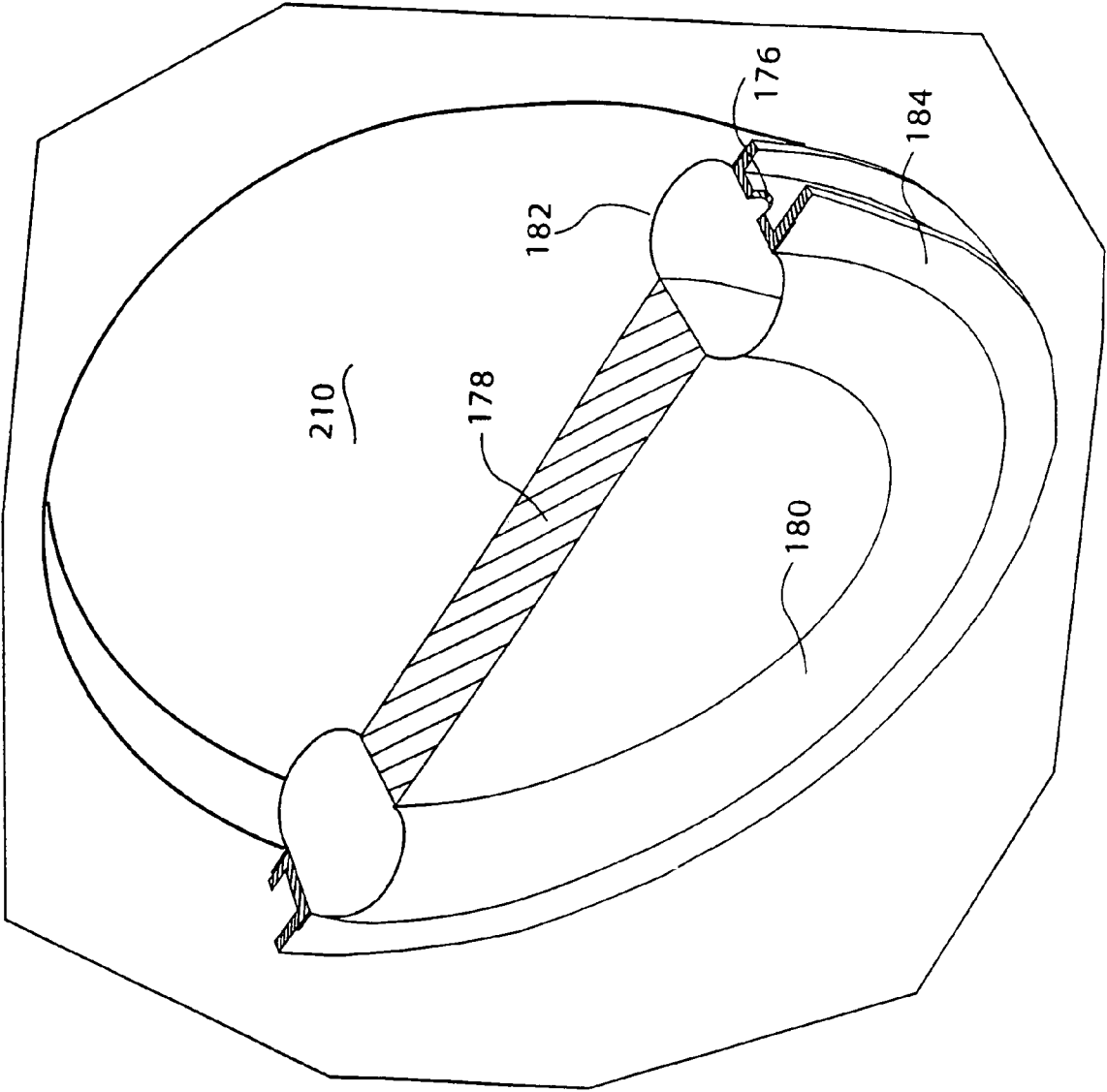

FIG-19

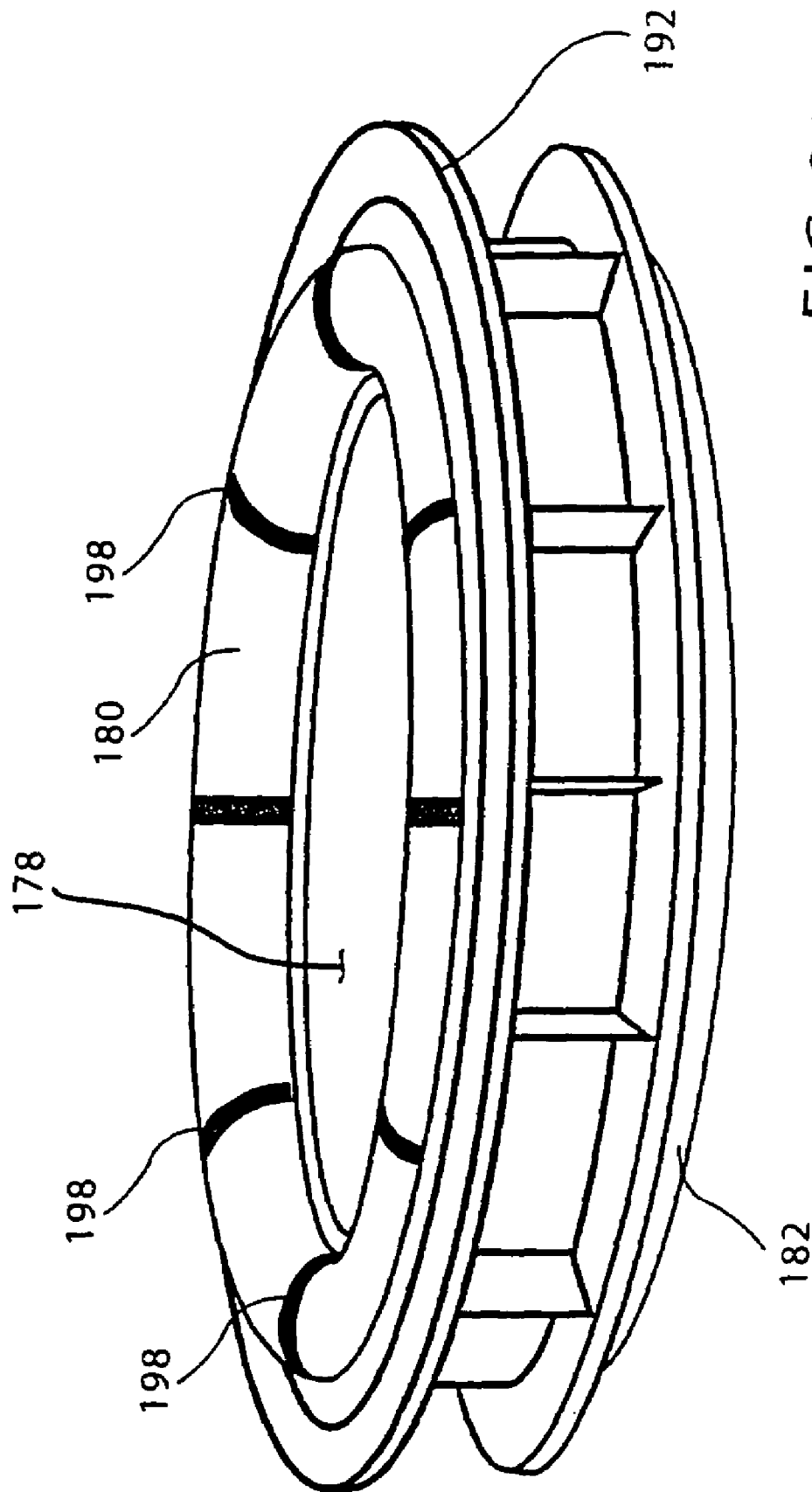

FIG-20

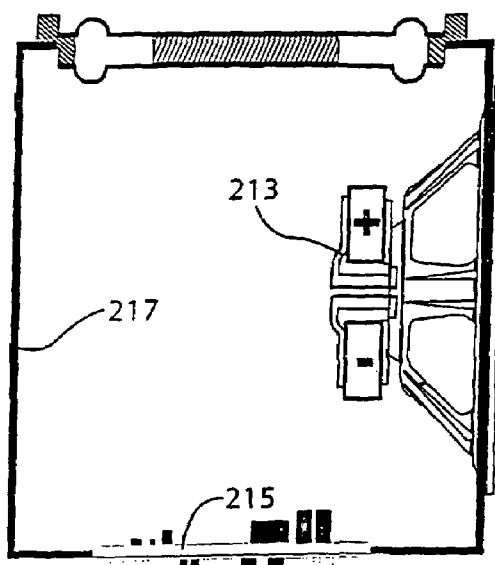

FIG-21

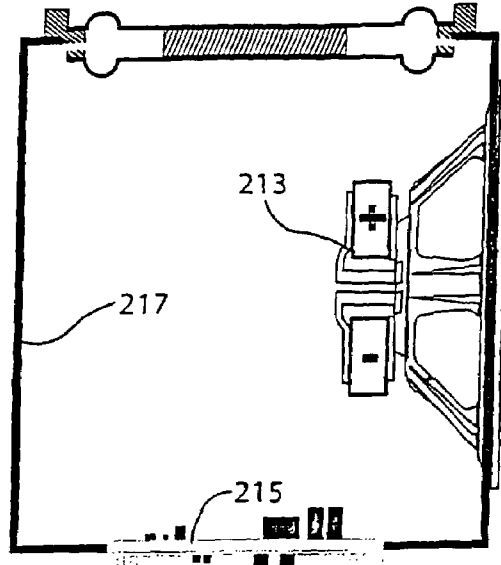

FIG-22

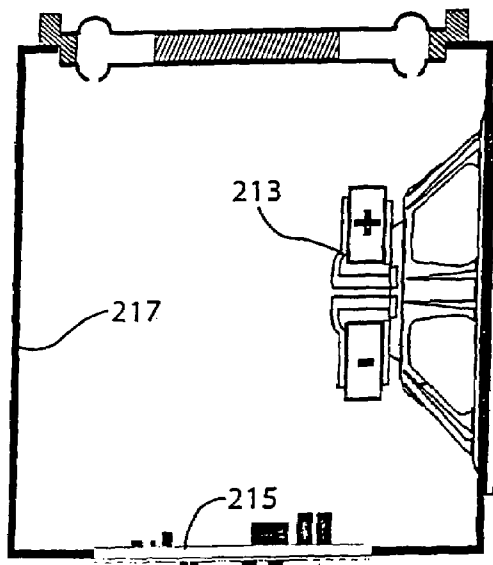

FIG-23

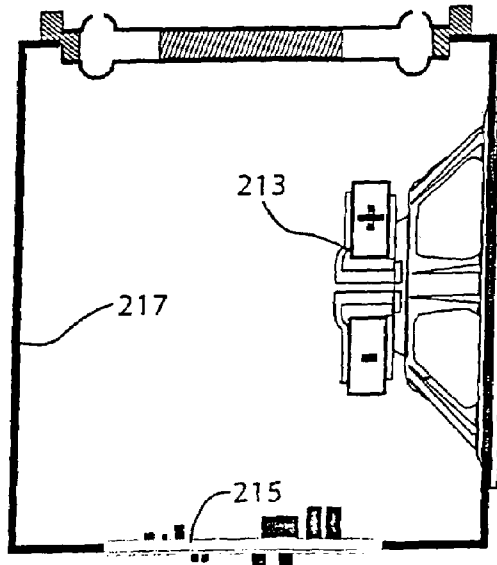

FIG-24

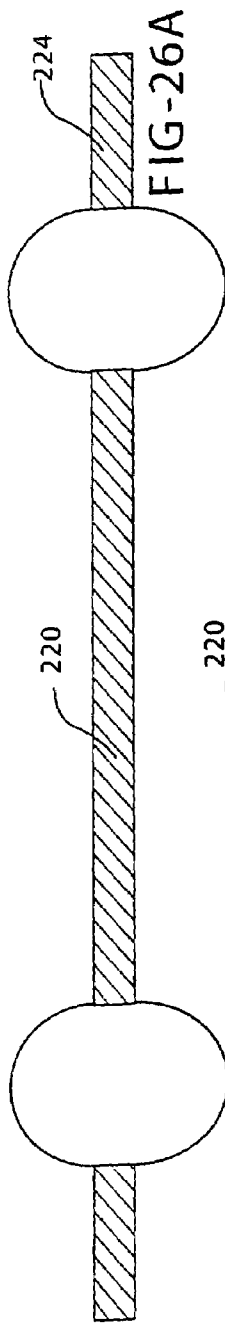

FIG-26A

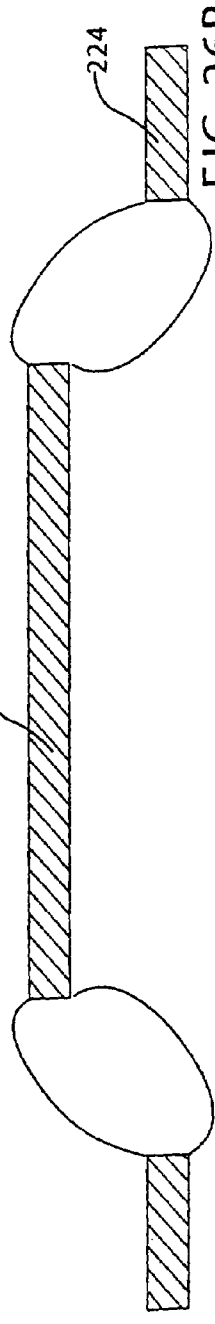

FIG-26B

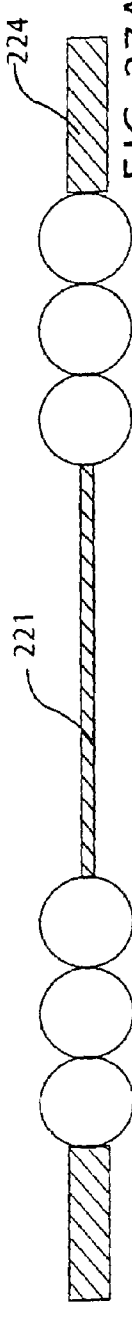

FIG-27A

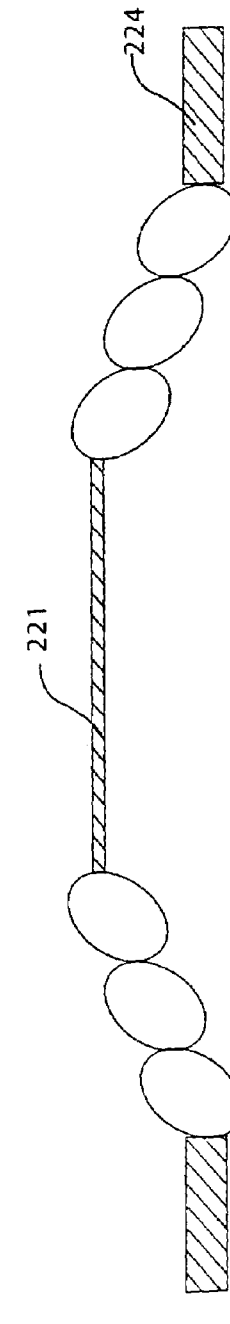
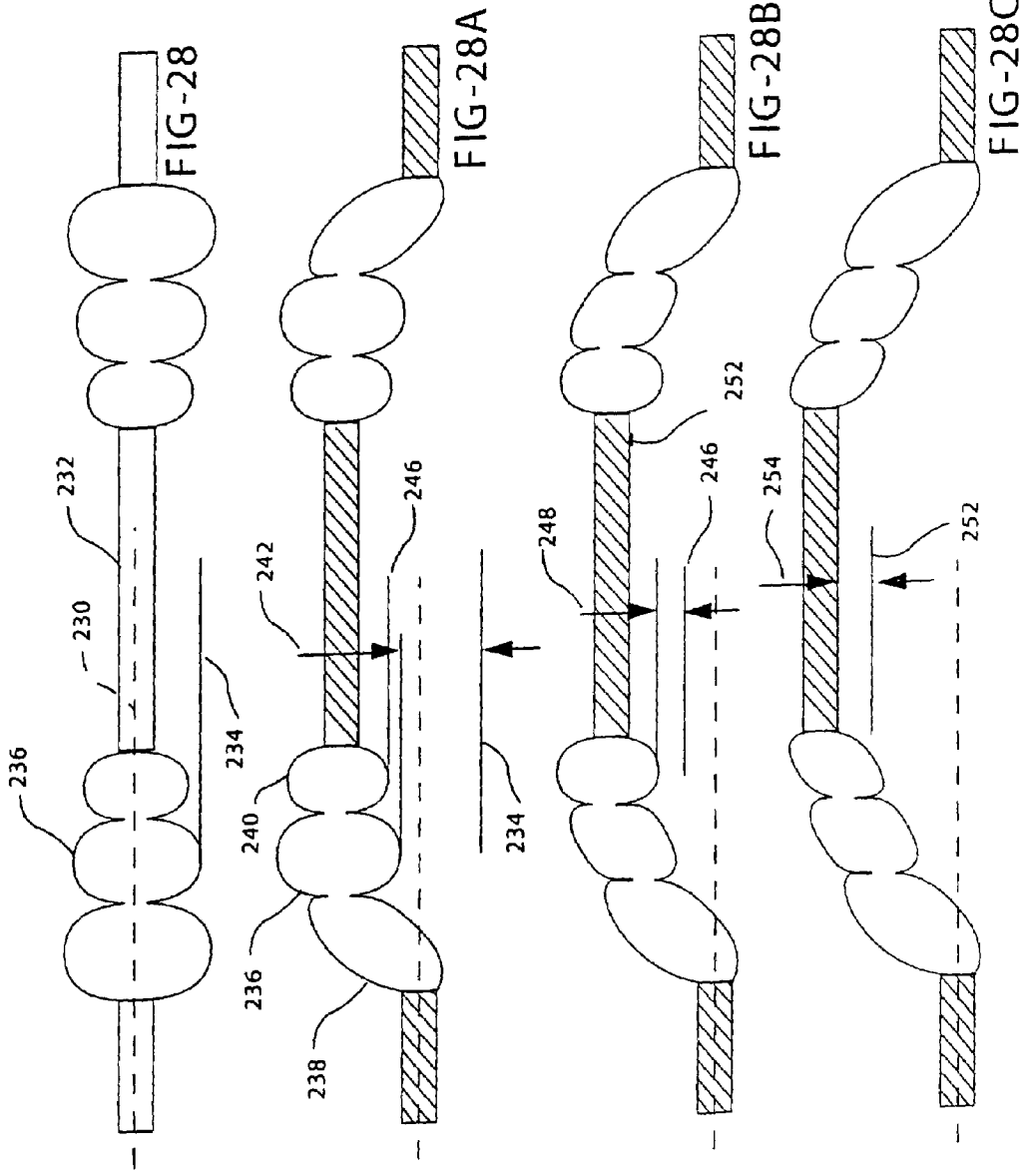

FIG-27B



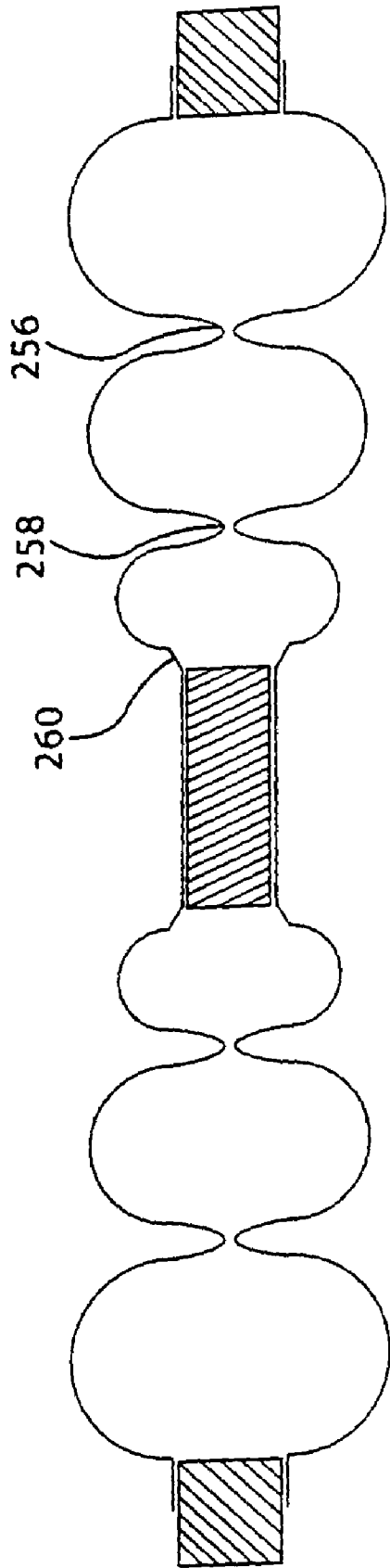

FIG-29

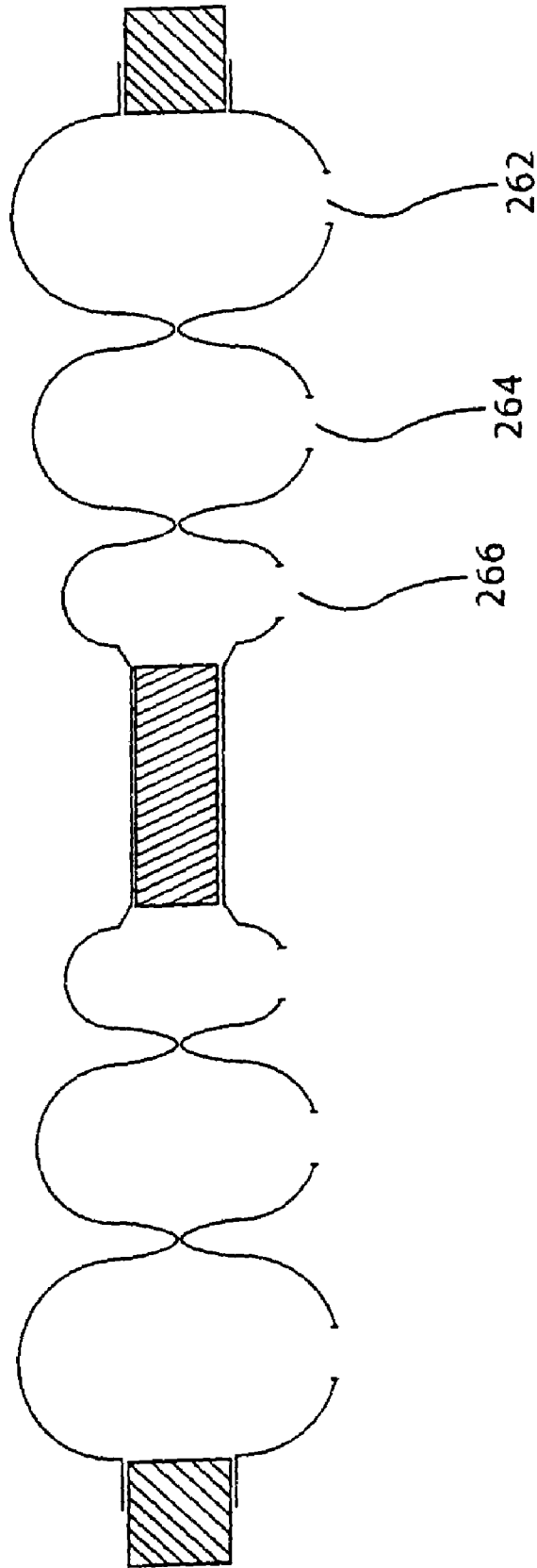

FIG-30

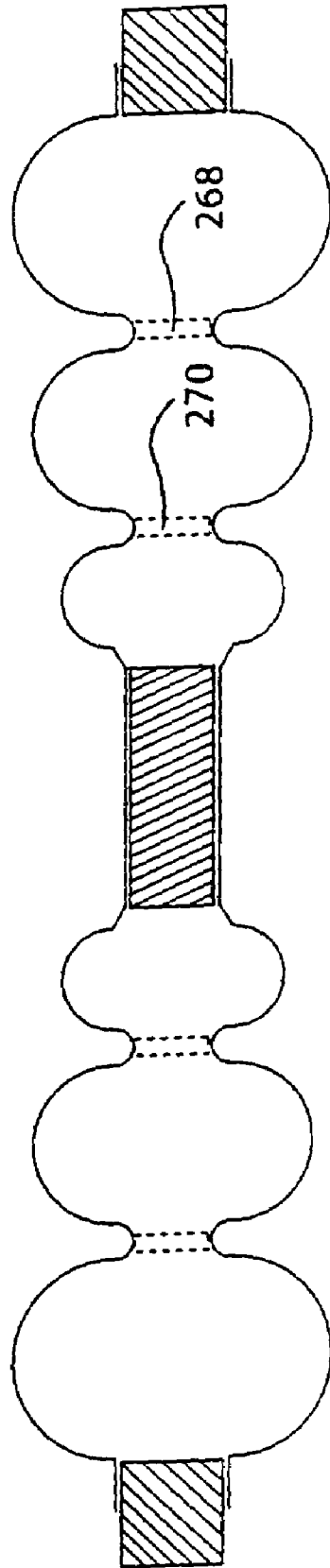

FIG-31

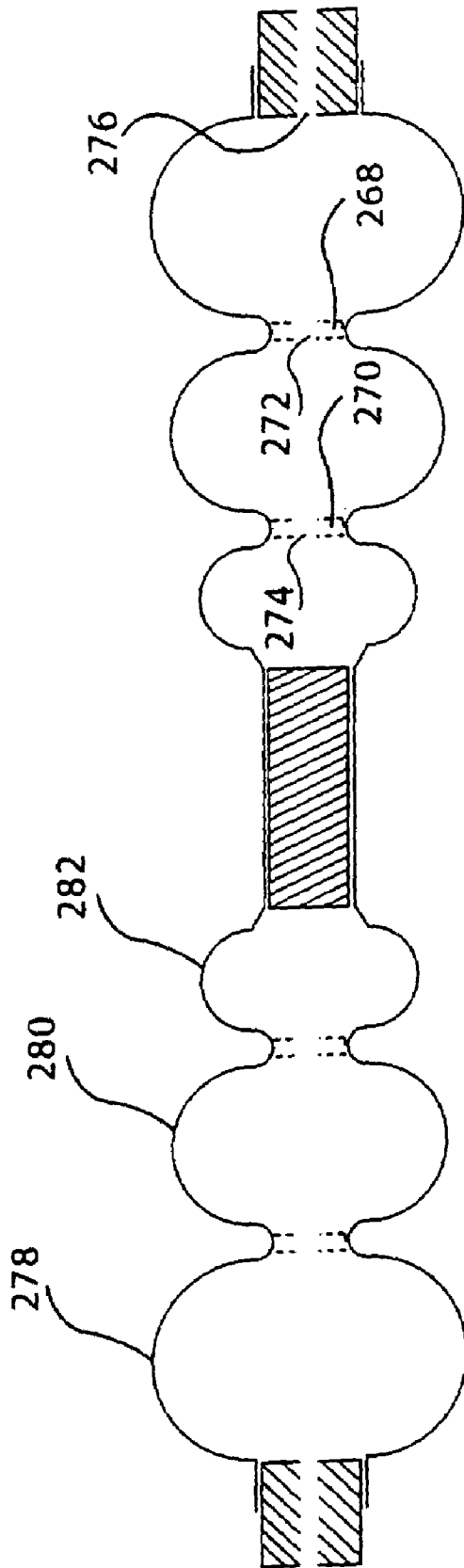

FIG-32

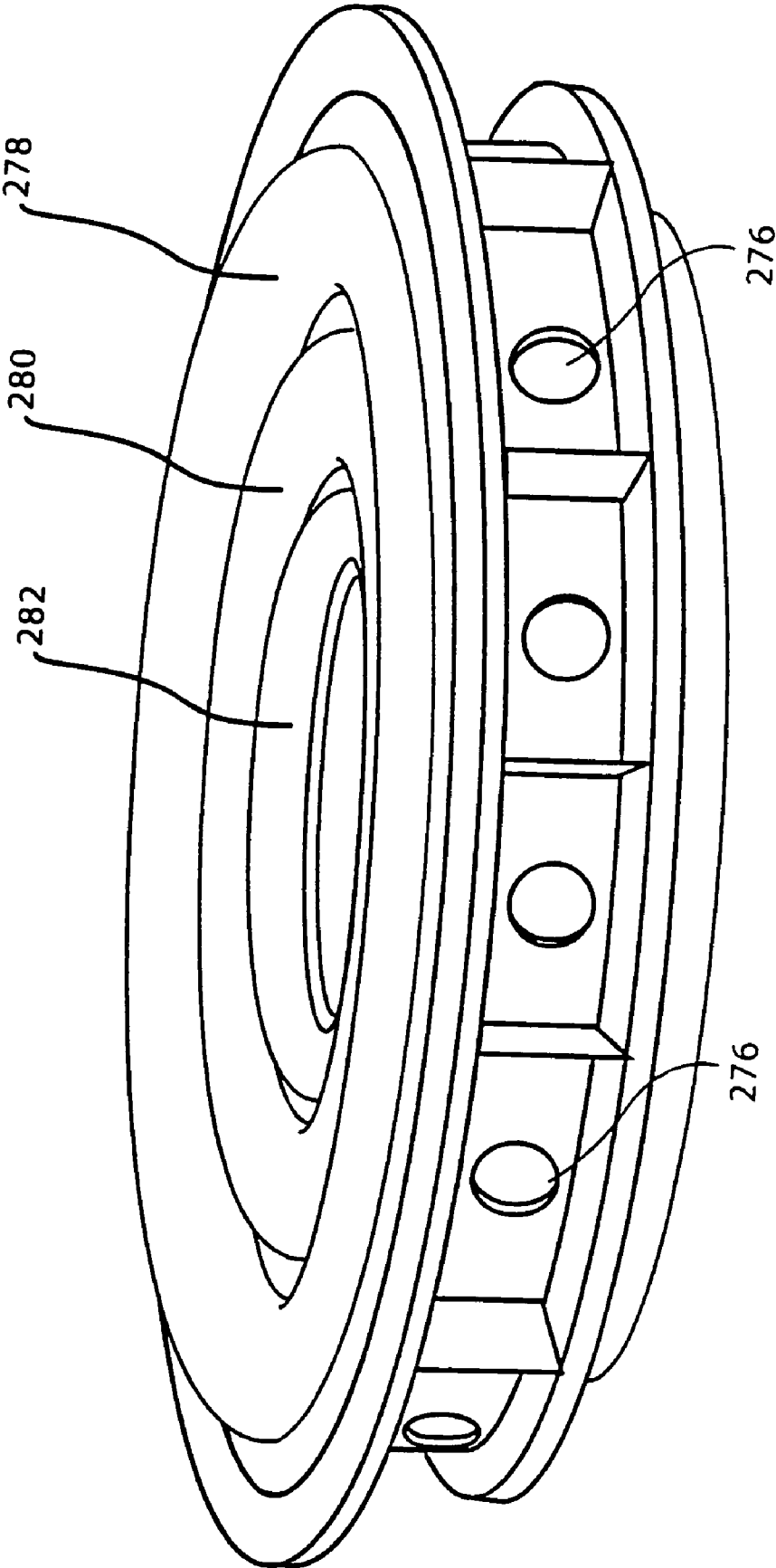

FIG-33

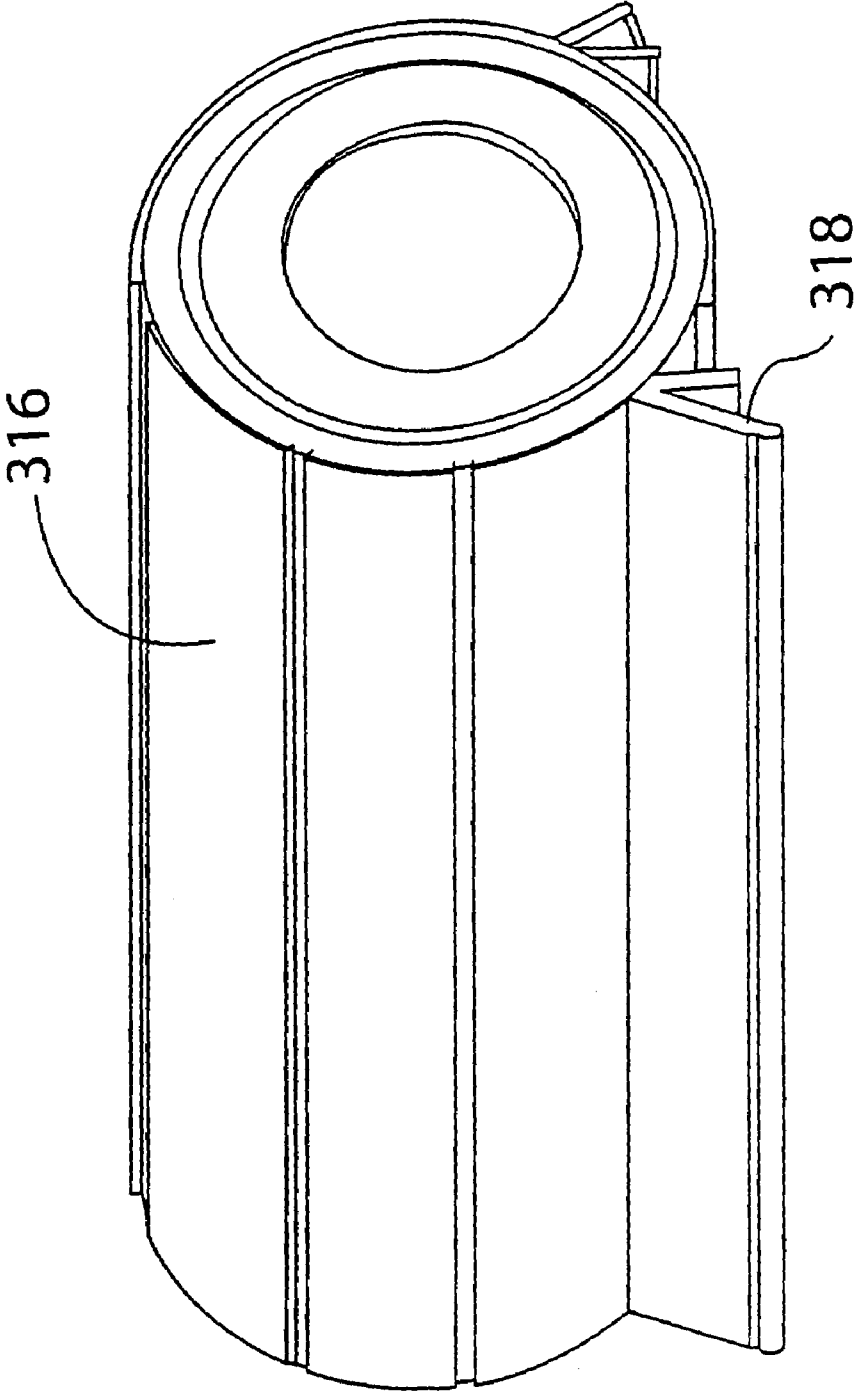

FIG-34

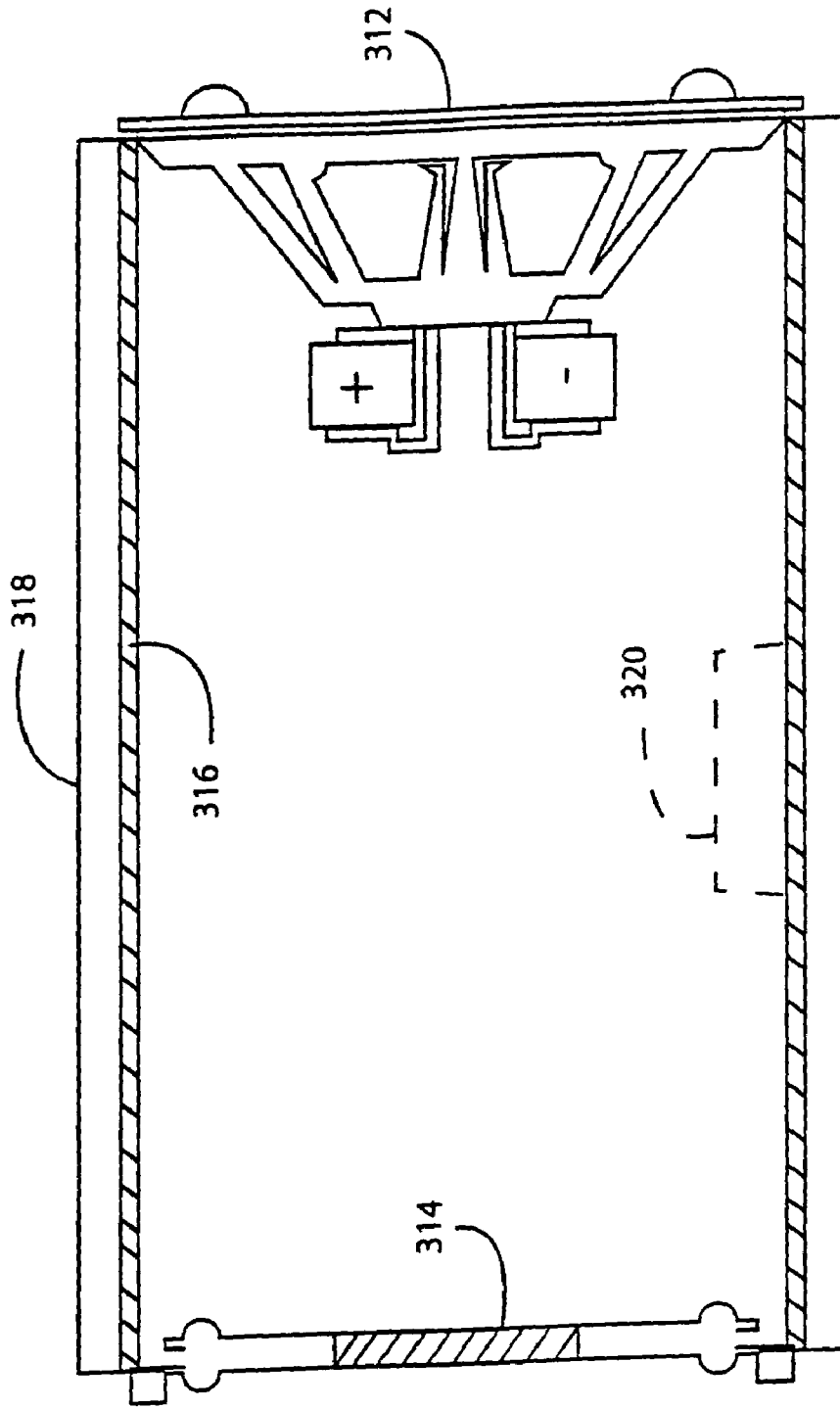

FIG-35

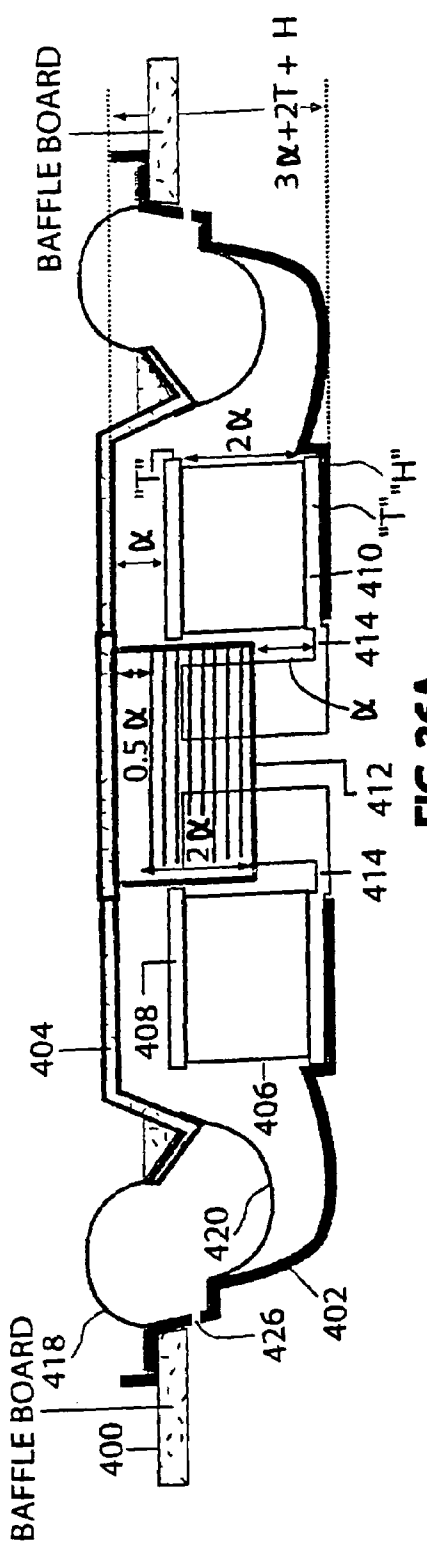

FIG. 36A

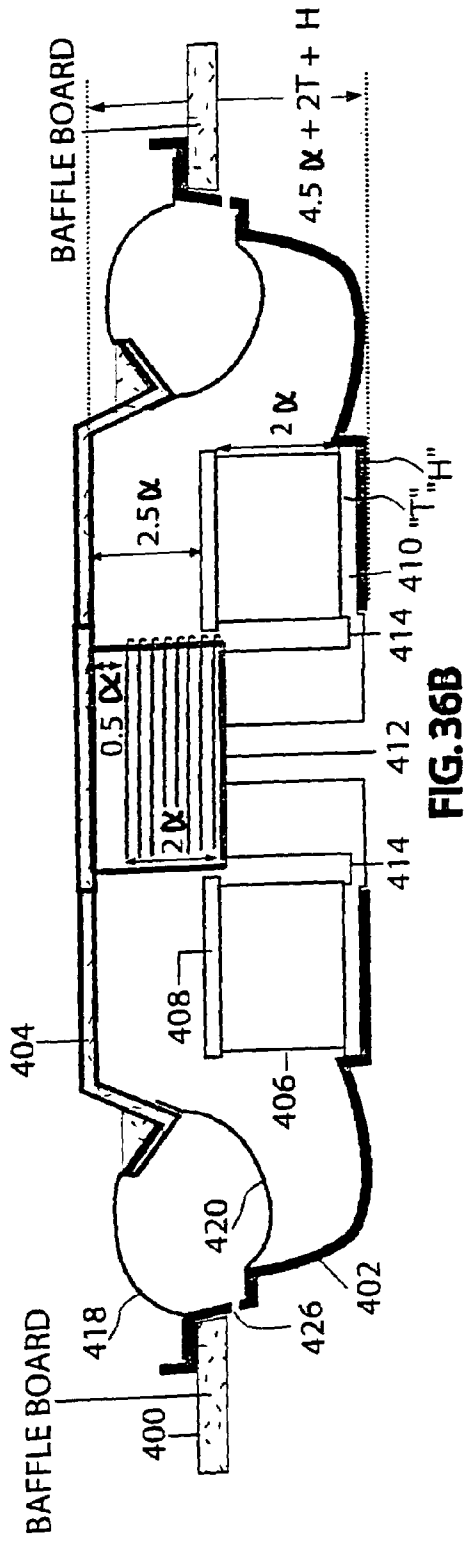

FIG. 36B

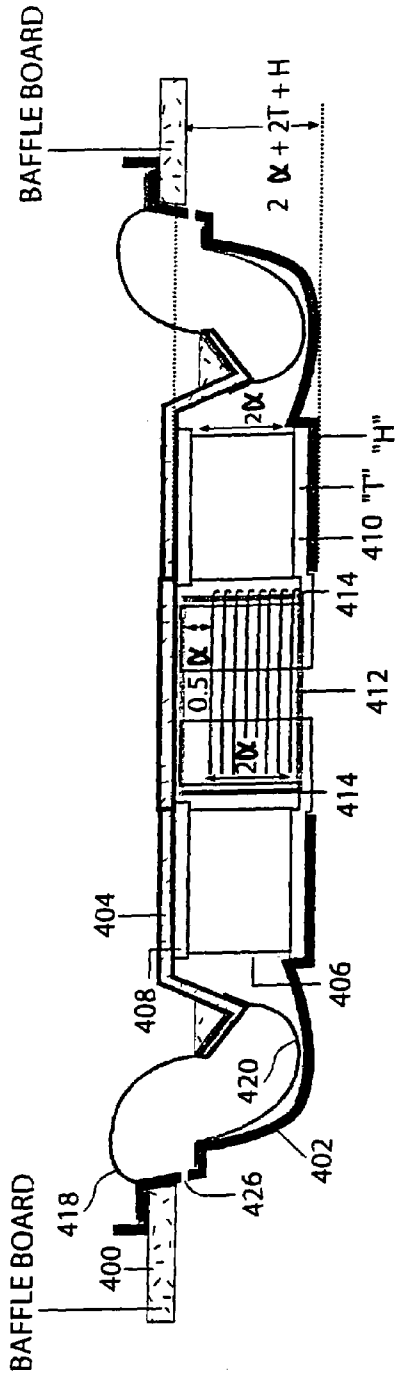

FIG. 36C

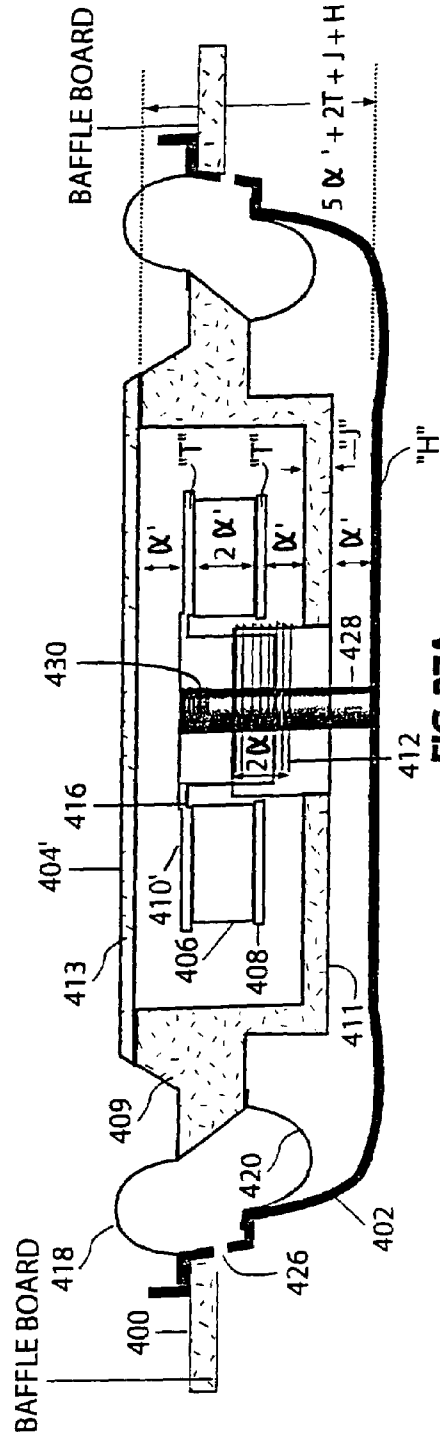

FIG. 37A

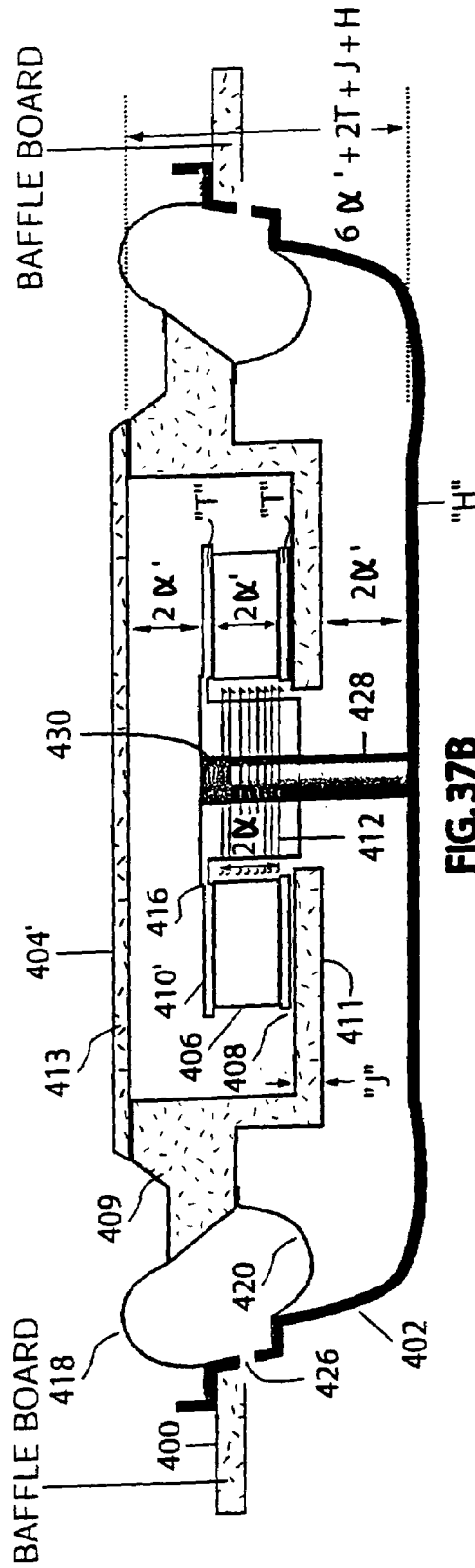

FIG. 37B

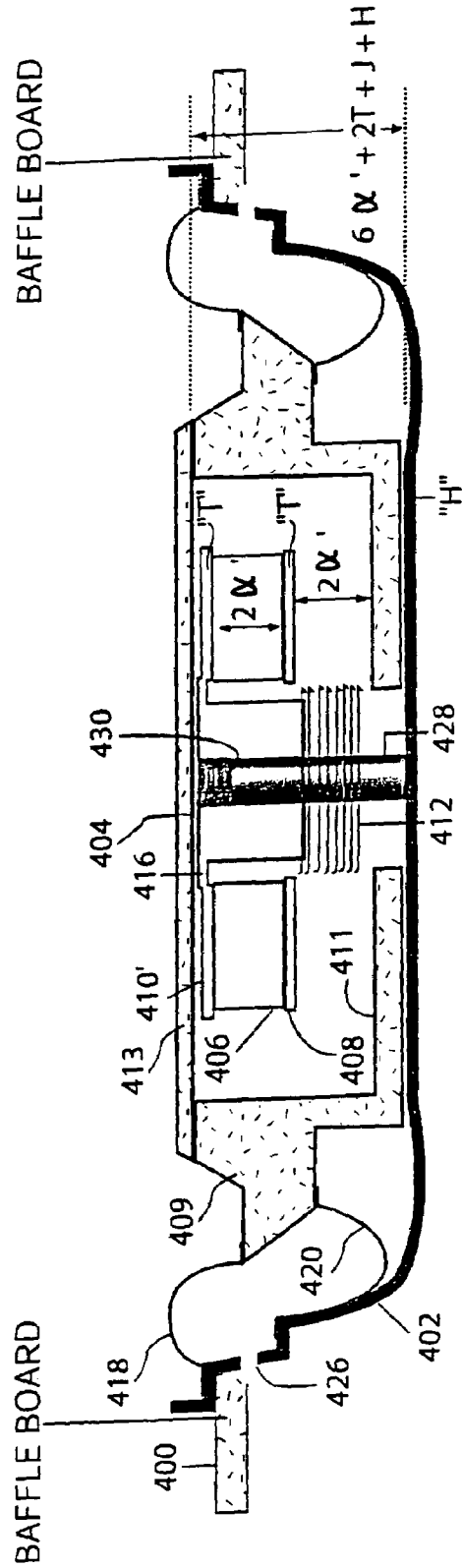

FIG. 37C

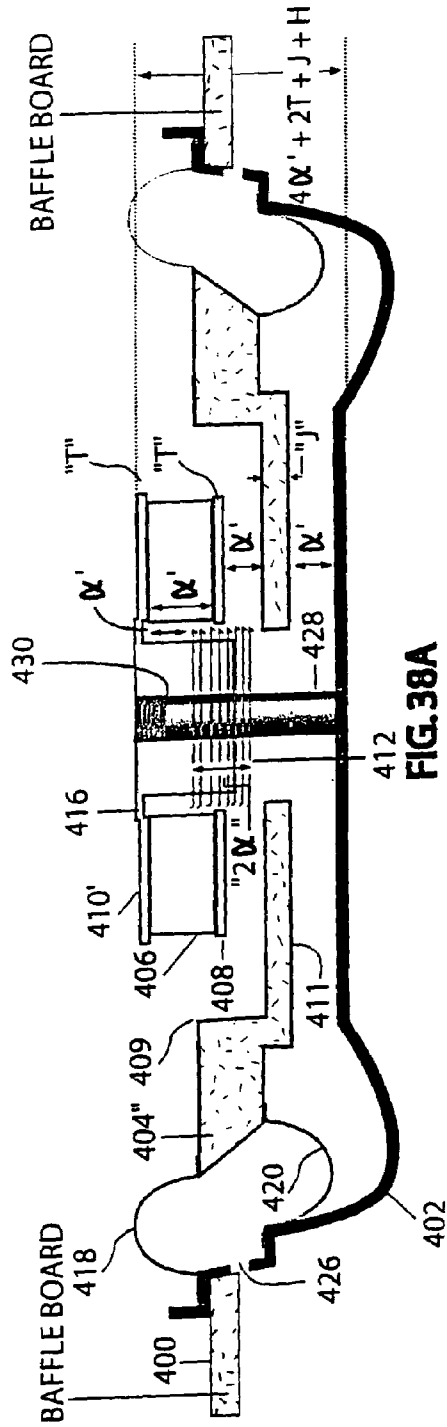

FIG. 38A

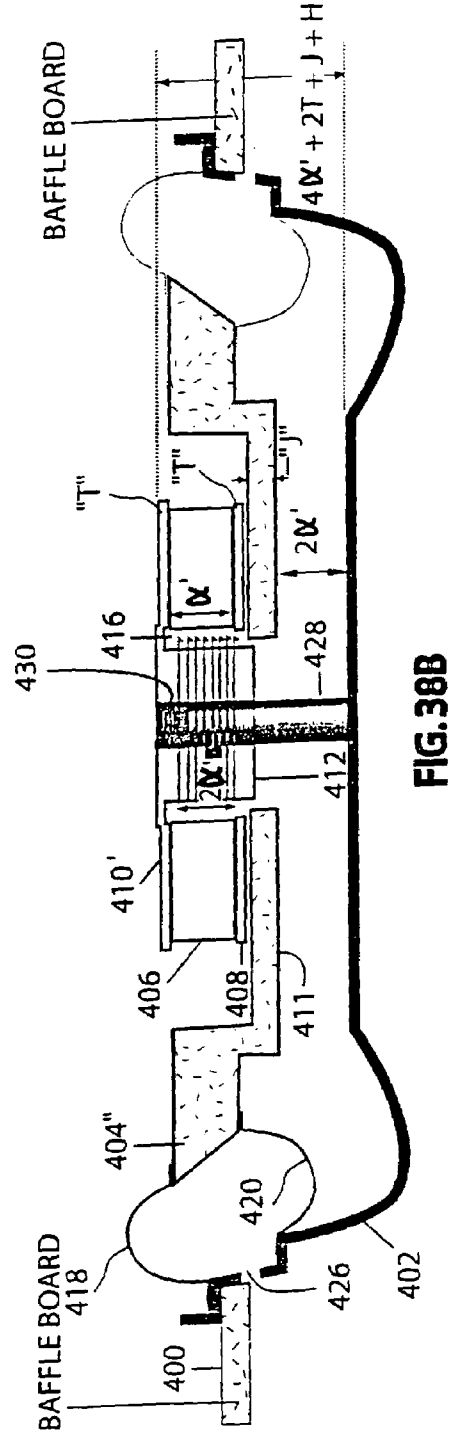

FIG. 38B

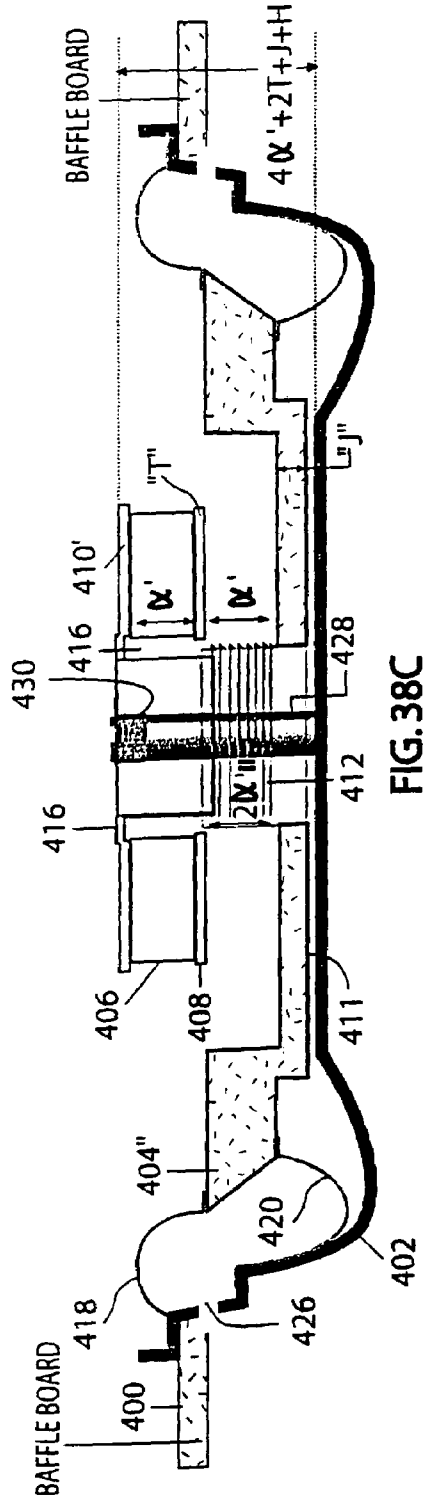

FIG. 38C

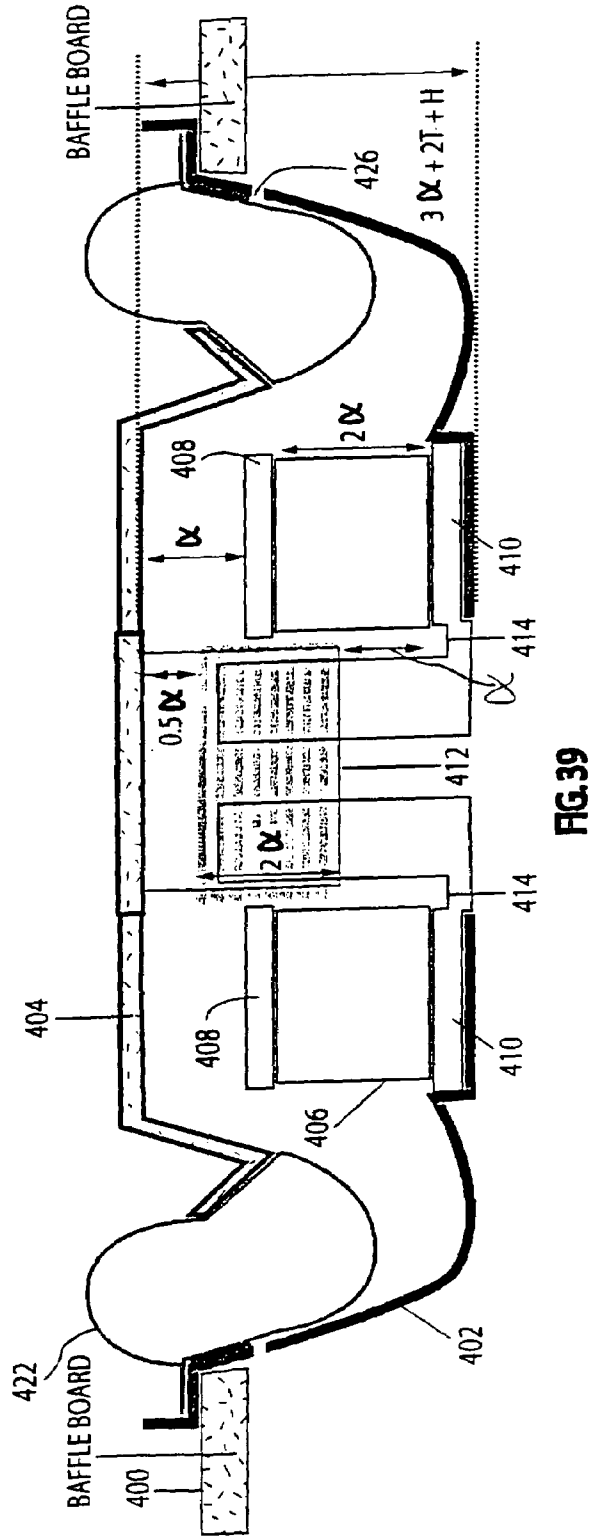

FIG. 39

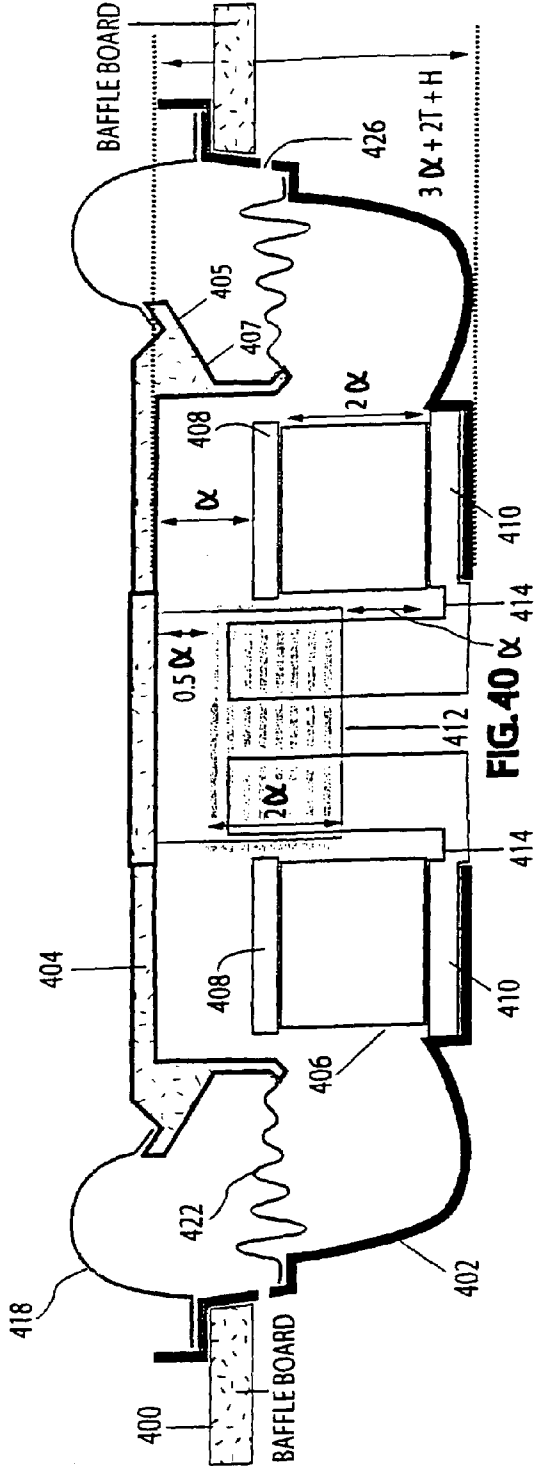

FIG. 40

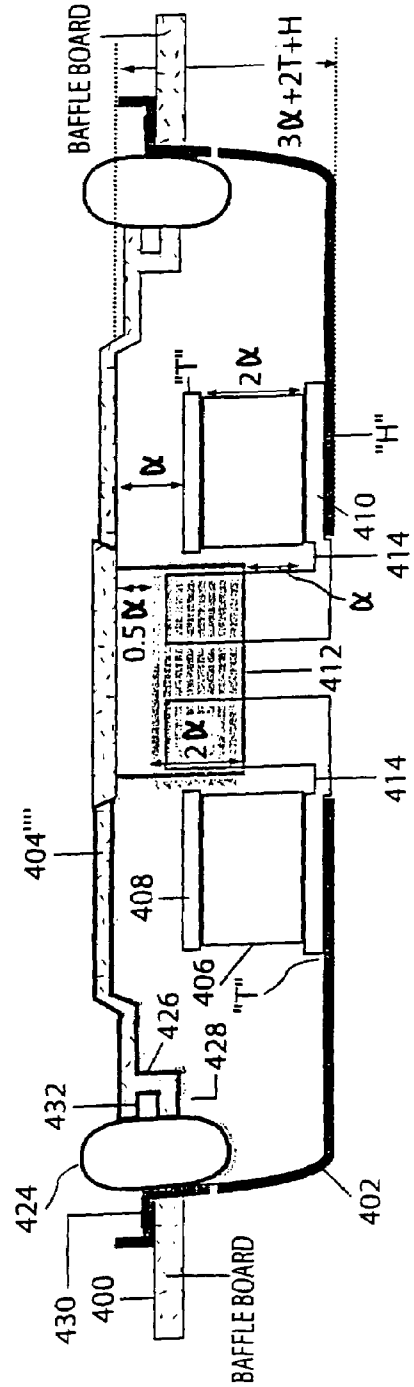

FIG. 41A

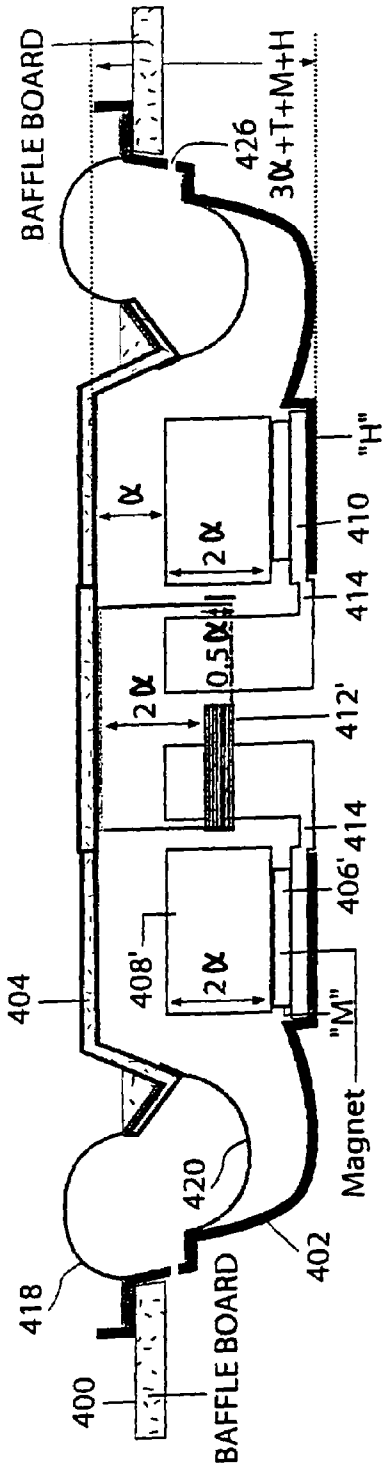

FIG. 42A

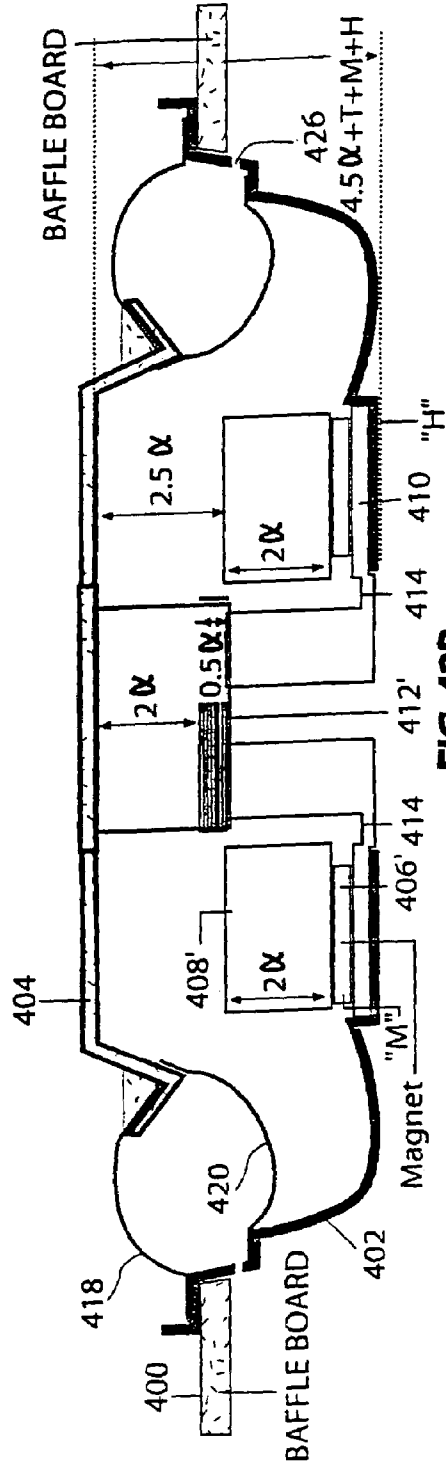

FIG. 42B

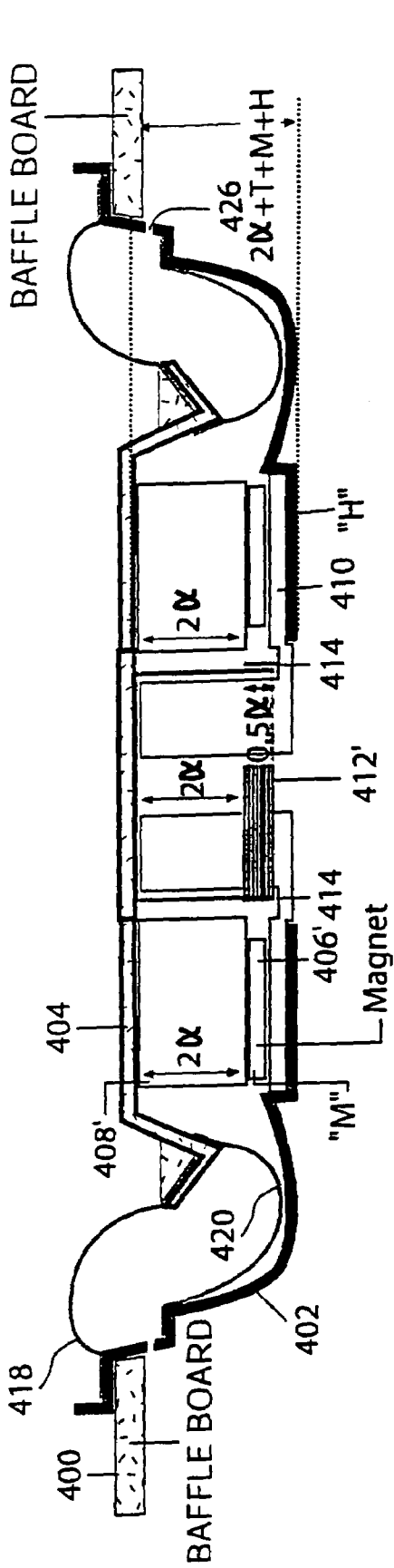

FIG. 42C

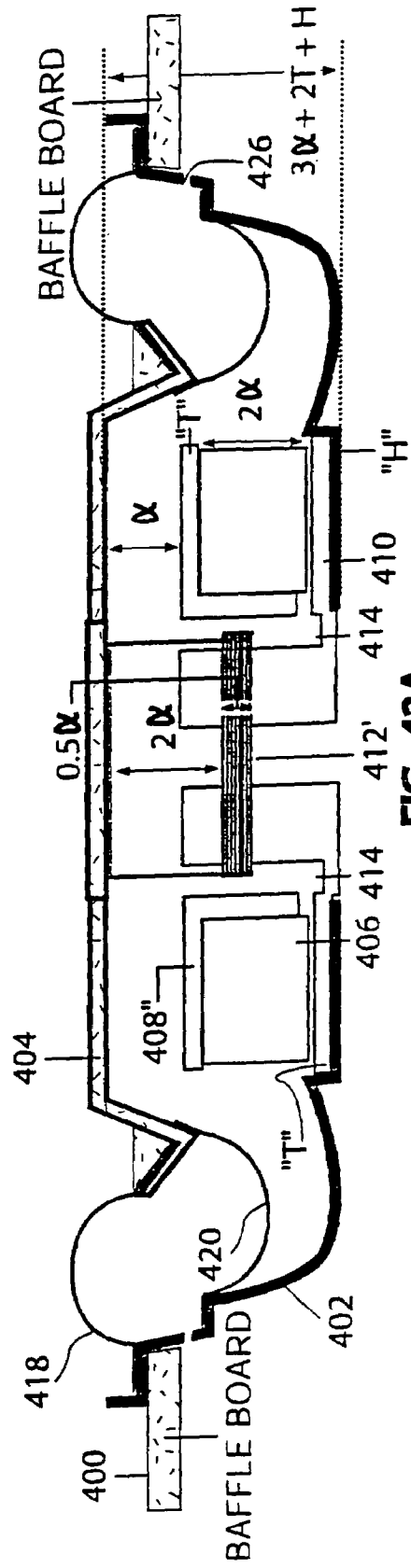

FIG. 43A

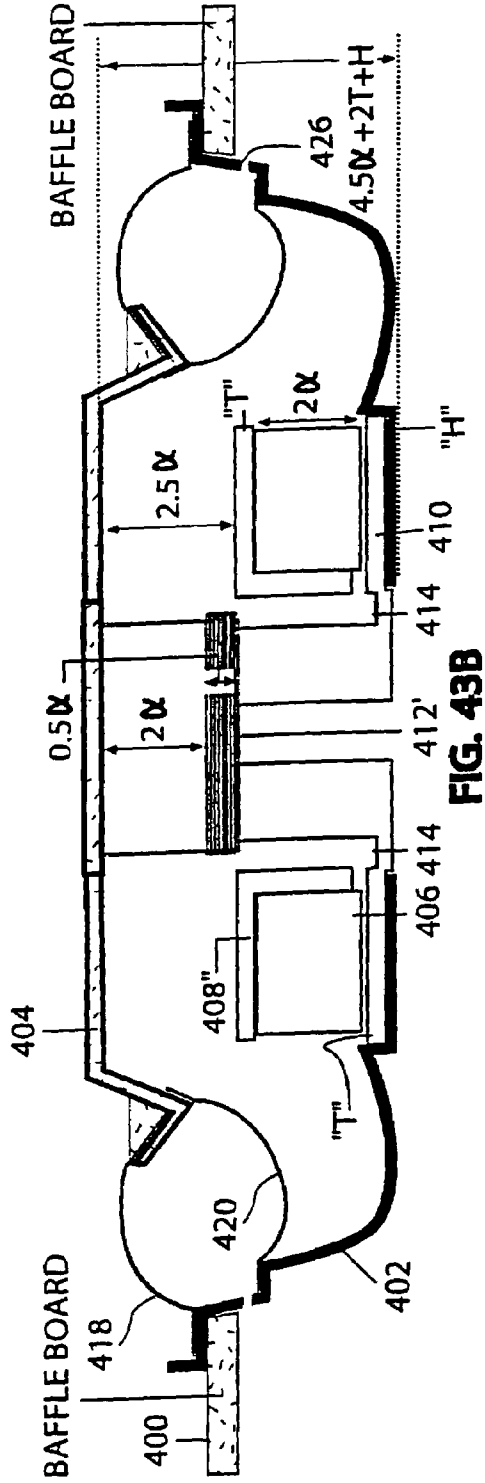

FIG. 43B

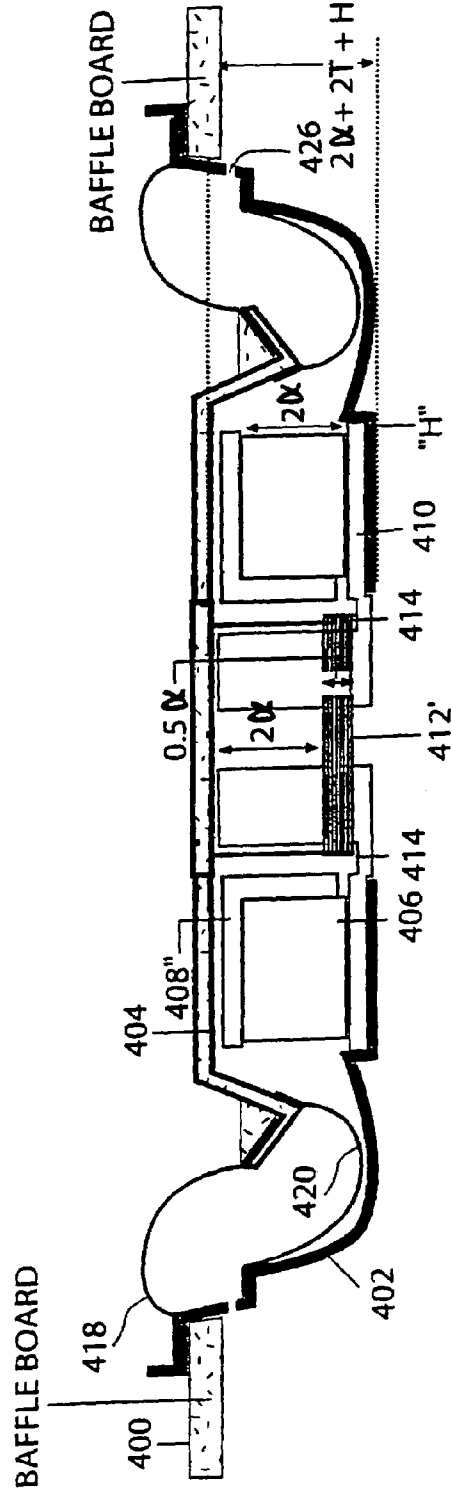

FIG. 43C

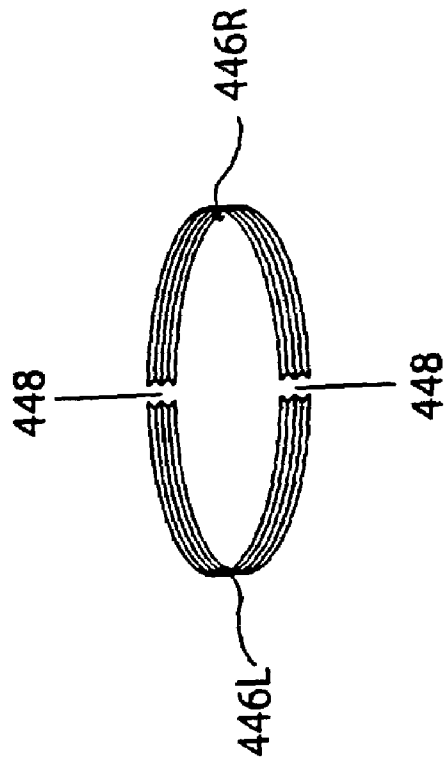

FIG. 44B

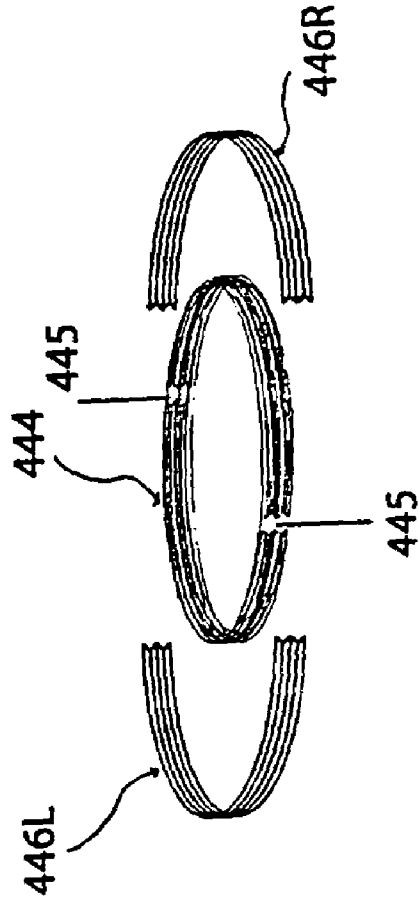

FIG. 44A

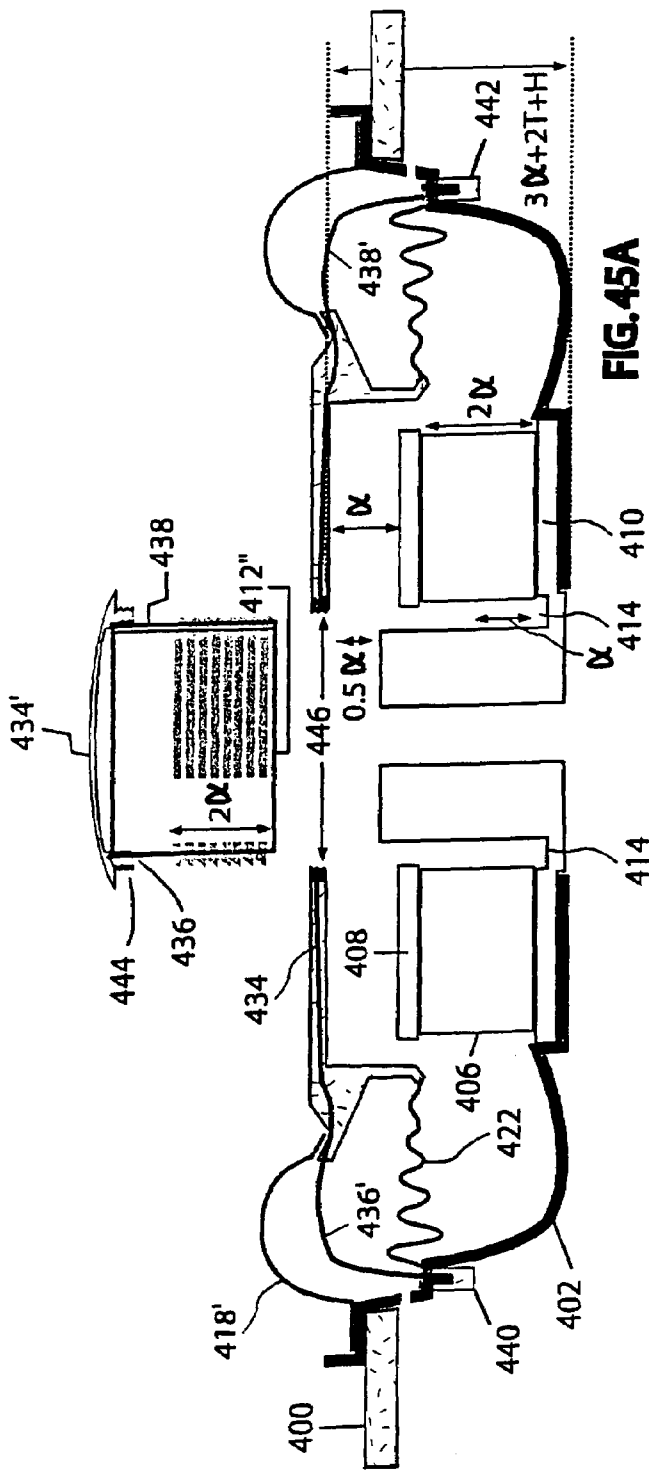

FIG. 45A

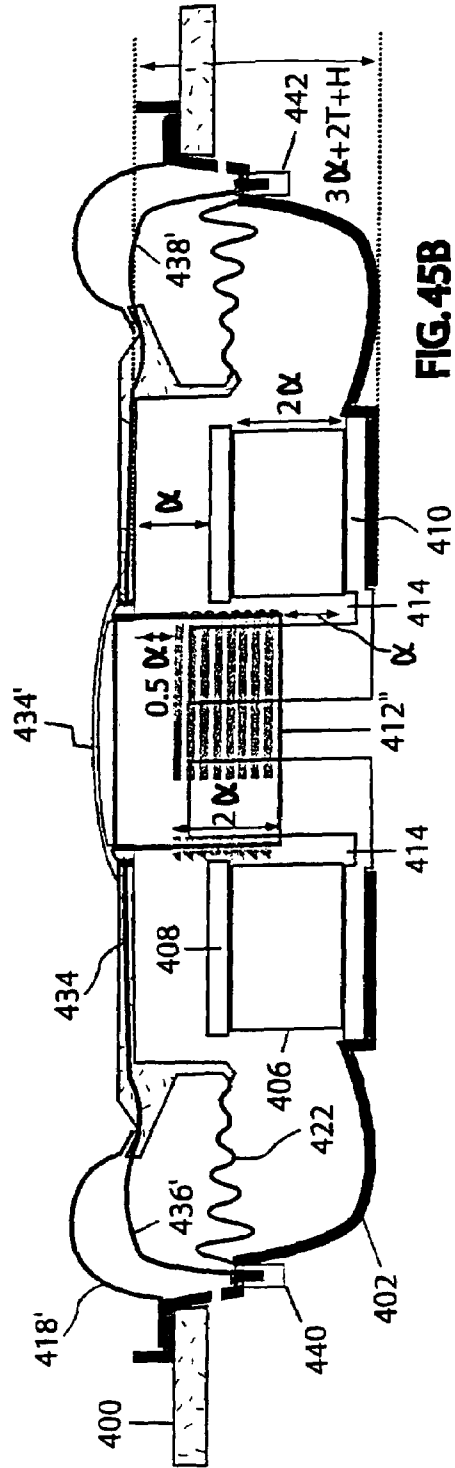
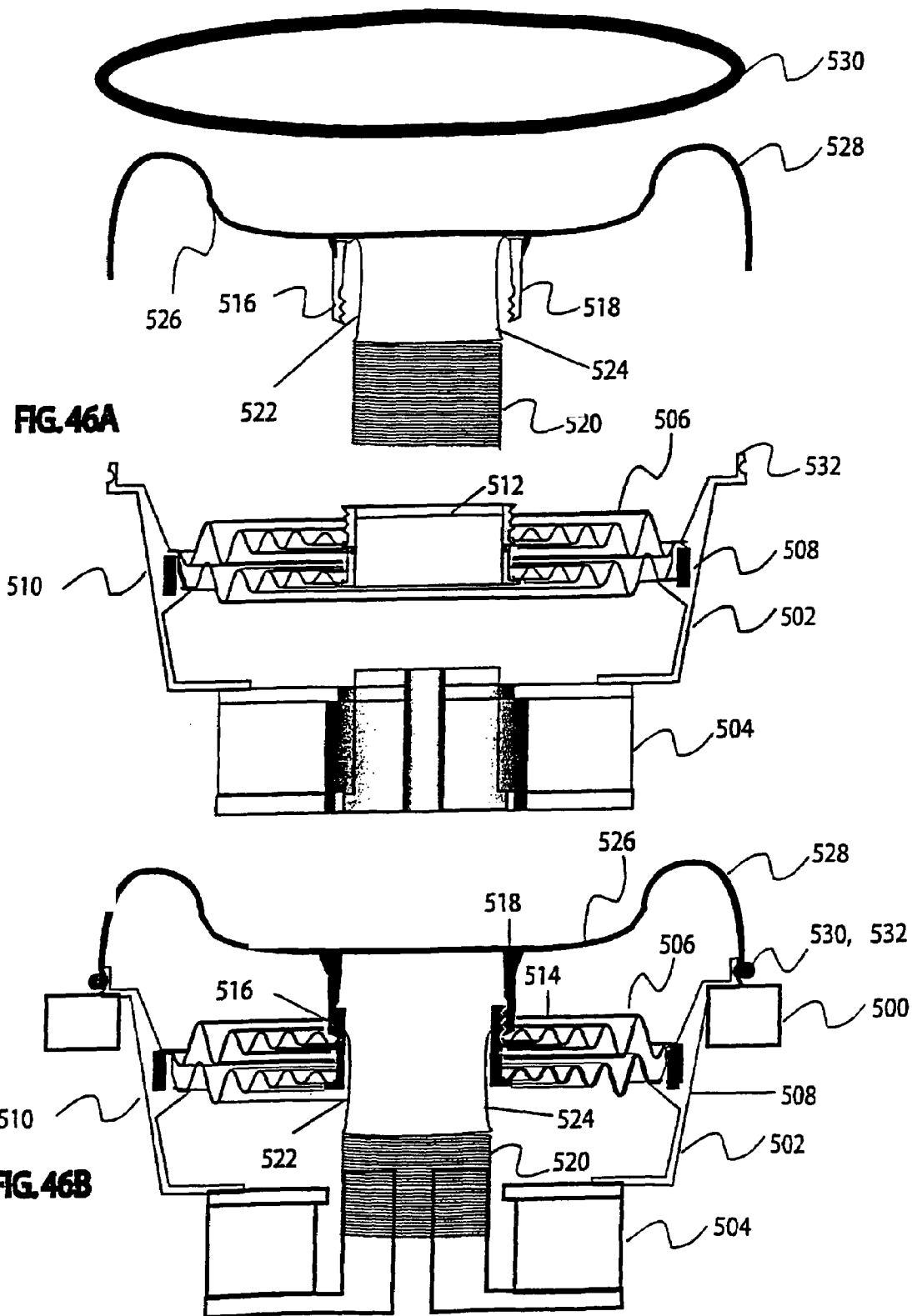
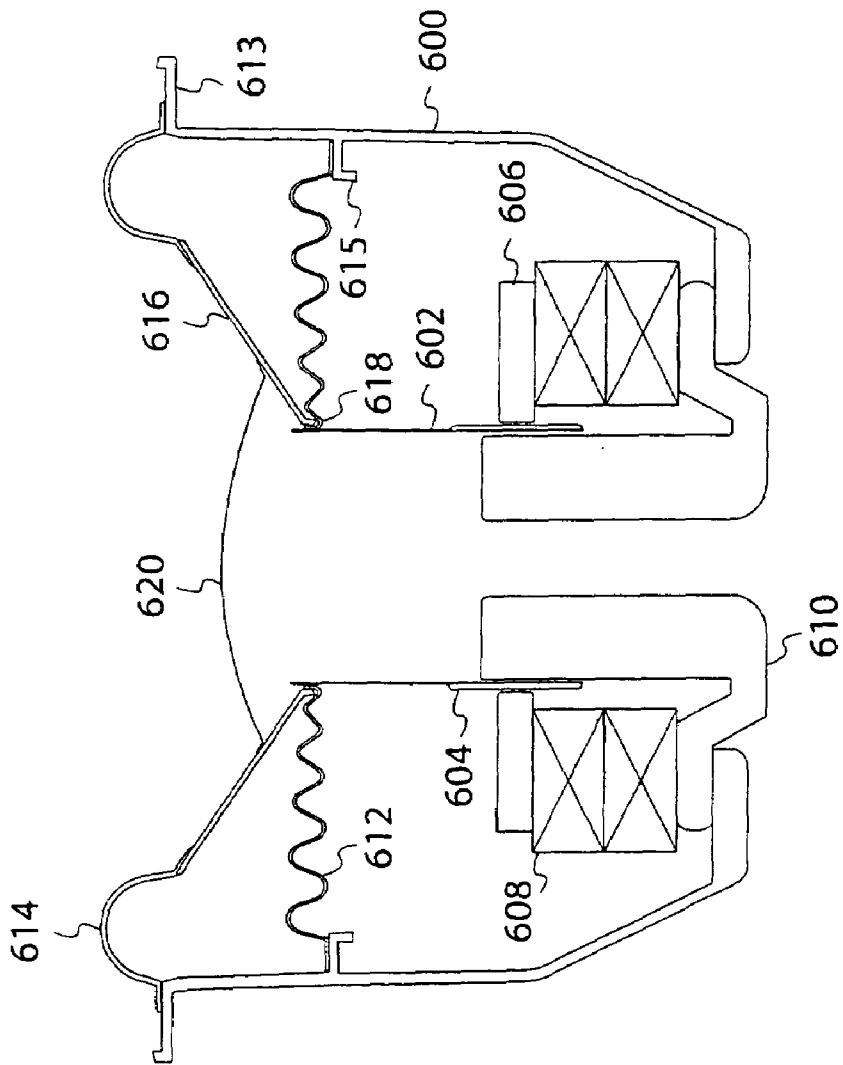

FIG. 45B



C"



(PRIOR ART)

FIG. 47

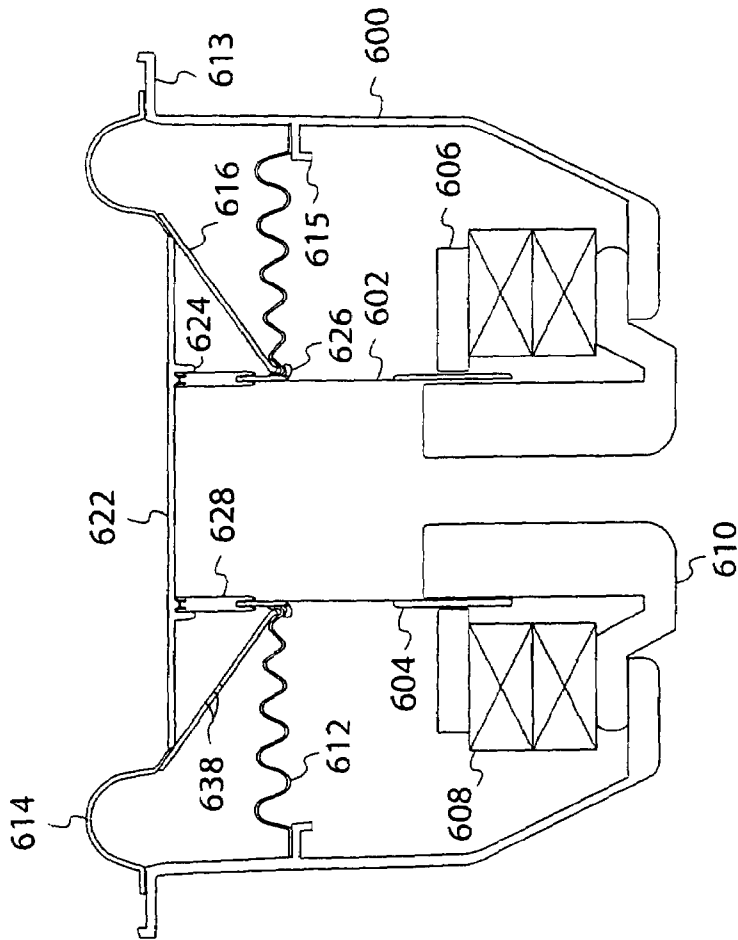

FIG. 48A

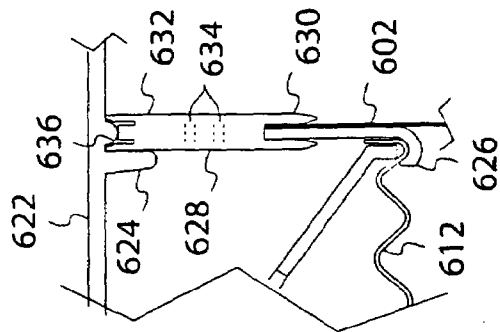

FIG. 48B

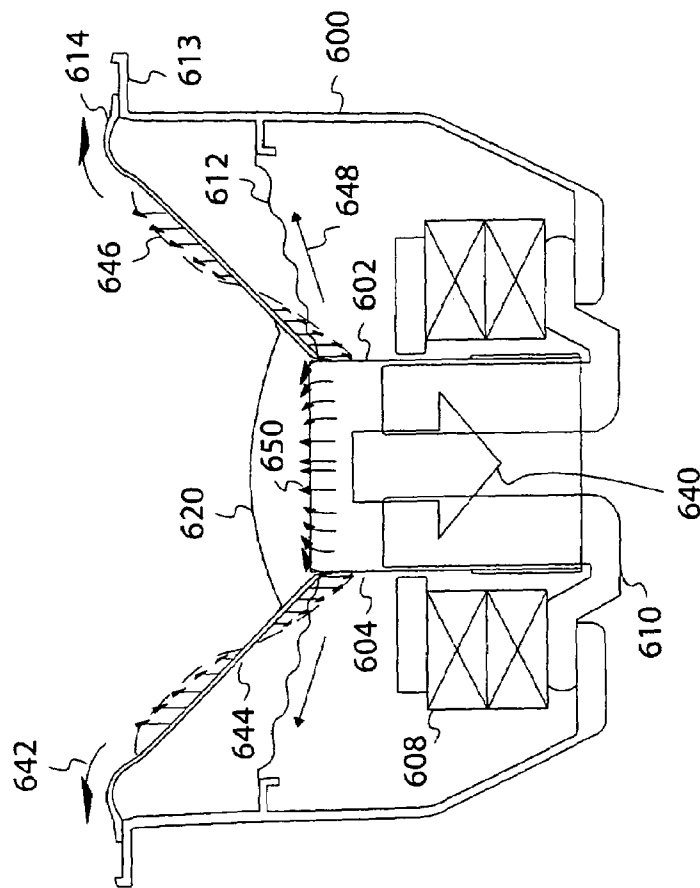

FIG. 49A

(PRIOR ART)

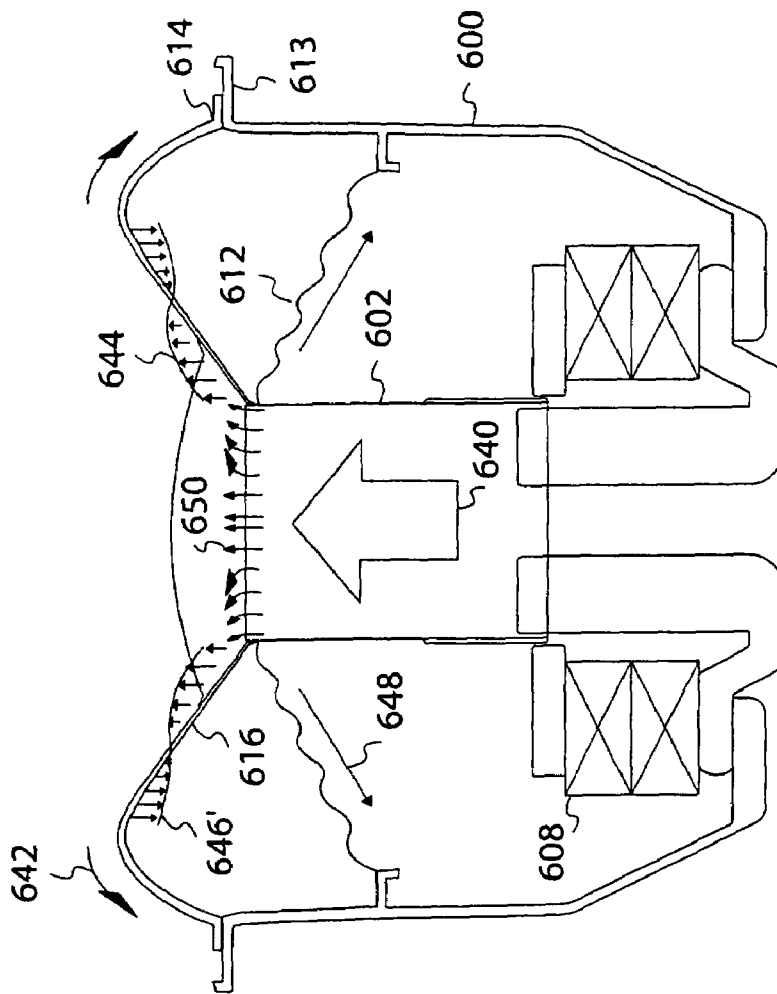

FIG. 49B

(PRIOR ART)

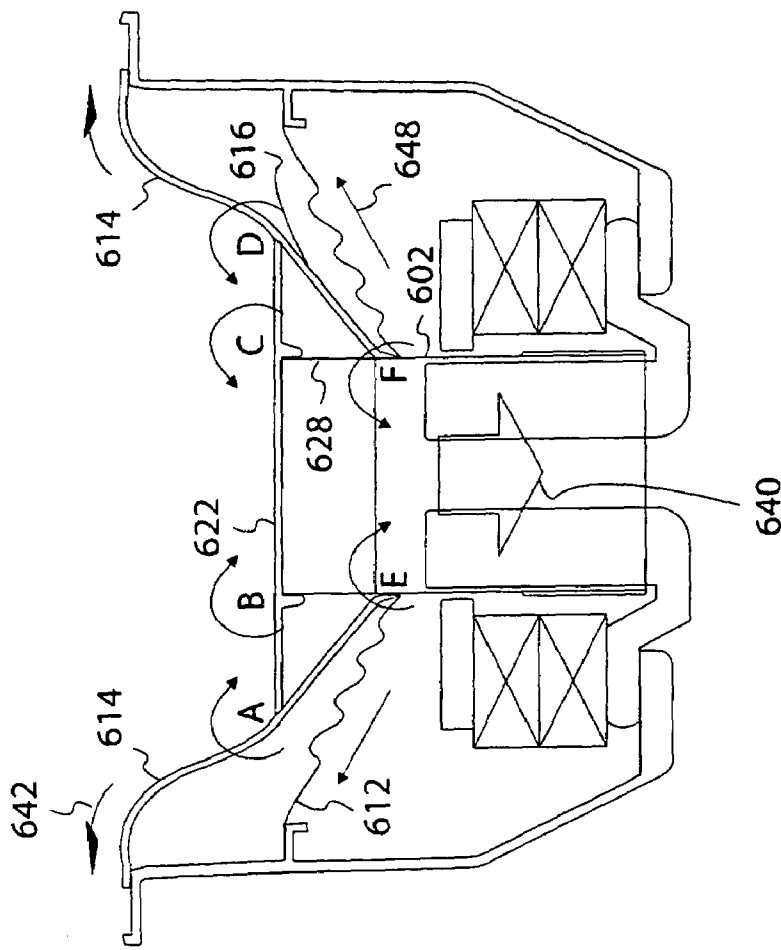

FIG. 50A

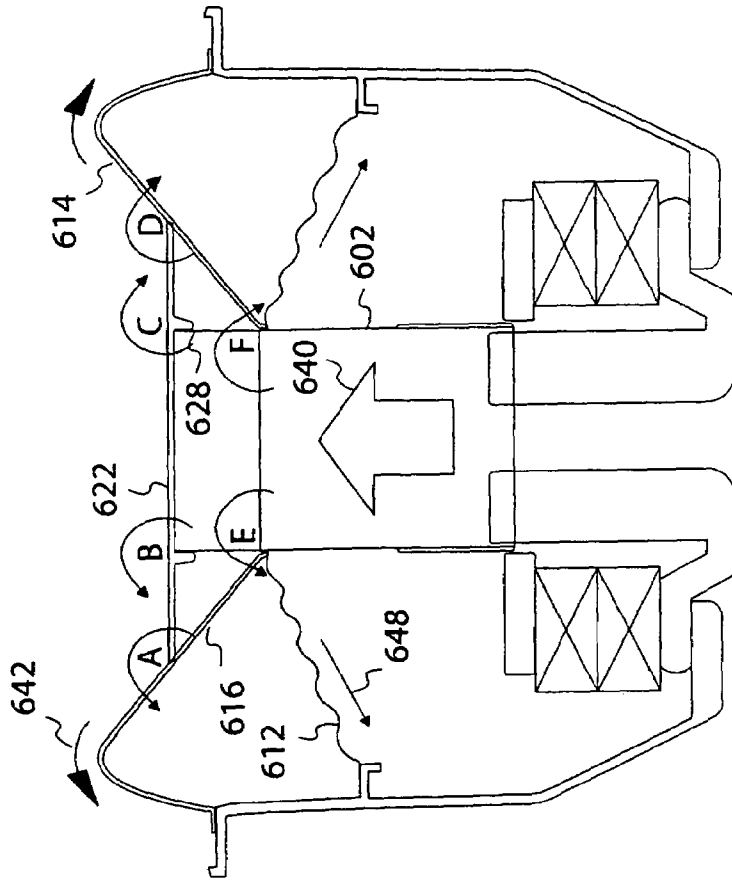

FIG. 50B

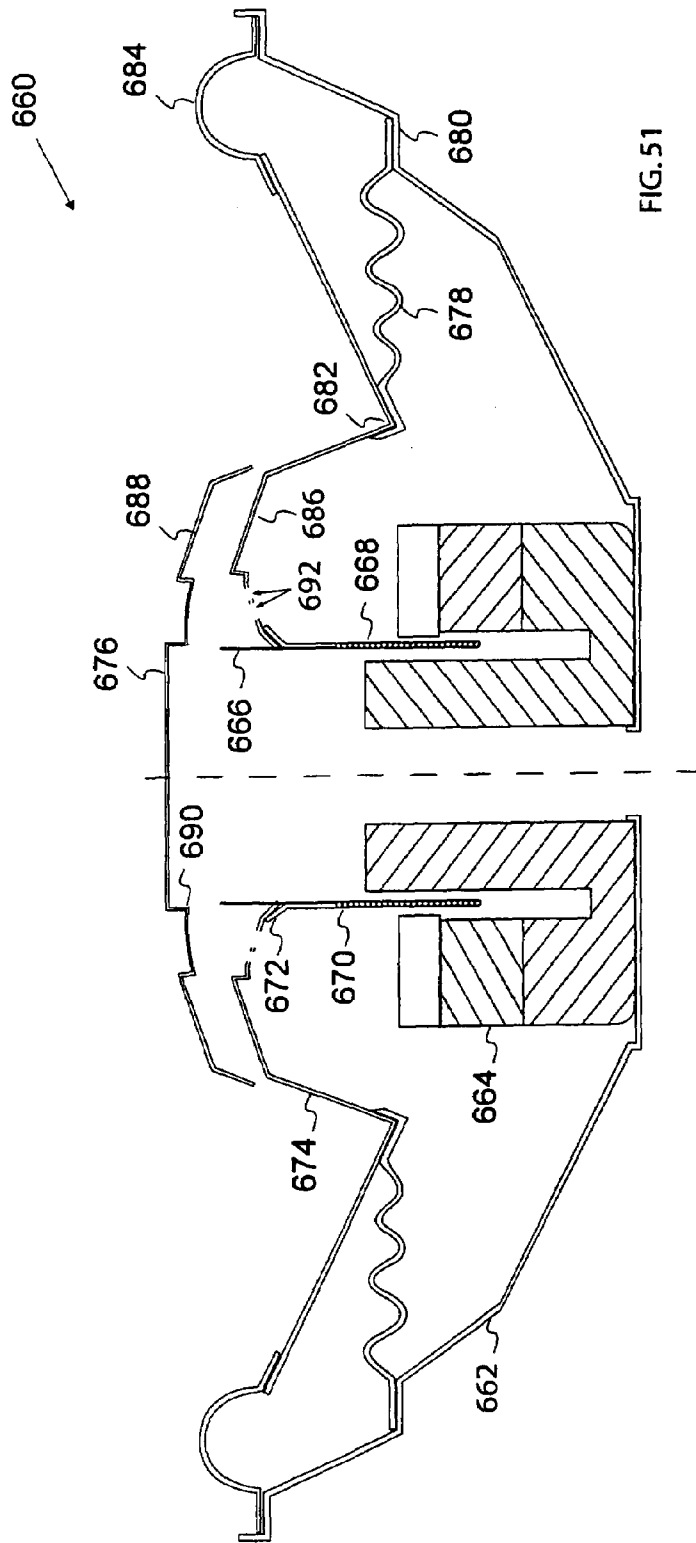

FIG. 51

AUDIO SPEAKER WITH WOBBLE FREE VOICE COIL MOVEMENT

CROSS-REFERENCE

This application is a Continuation-In-Part of application Ser. No. 10/058,868, filed Jan. 28, 2002 (now U.S. Pat. No. 6,675,931, issued Jan. 13, 2004), which is a Continuation-In-Part application Ser. No. 09/542,155, filed Apr. 4, 2000 (now U.S. Pat. No. 6,460,651, issued Oct. 8, 2002), which is a Continuation In Part application of application Ser. No. 09/201,398, filed Nov. 30, 1998 (now U.S. Pat. No. 6,044,925 issued Apr. 4, 2000).

BACKGROUND OF THE INVENTION

1. Field of the Invention

This invention relates to loud speakers and in particular to the construction of audio speakers that have virtually no wobble of the voice coil bobbin during operation.

2. Description of the Related Art

A goal of sound reproduction equipment is to provide a life-like sound quality to the listener. Lifelike sound quality is understood to be best achieved when a sound system including the speakers have a flat frequency response curve throughout the range of sound frequencies audible to the human ear, generally 20 to 20,000 Hz. A normal speaker cabinet has an electro magnetically driven speaker cone sealed to an opening in the wall of a sealed cabinet. This arrangement provides a drooping frequency response curve (e.g., **22** in the graph **20** of FIG. 1).

The graph **20** of FIG. 1 represents a comparison of sound level verses frequency (i.e., frequency response). The plot **22** shows the drooping response for a closed cabinet system. Over the years, in an effort to improve sound quality low, mid, and high range speakers have been placed in separate cabinets or compartments. Each of those separate cabinets or compartments could then be tuned by creating ports, with or without tubes, in the cabinet to improve the frequency response. At low frequencies, the use of open ports, or open ports and tubes, in the speaker cabinet becomes unmanageable because of the large air mass that needs to be moved to provide adequate tuning. As an example, an ideal cabinet size to hear low frequencies might be larger than the room in which the listener was sitting.

In an effort to offset the effects of a rigid sealed cabinet and avoid the spatial requirements necessary when attempting to create ports or tube ports with speakers low frequencies, passive radiators (generally configured like speakers, but without the electro mechanical driver) have been placed in a secondary opening of the walls of the speaker cavity to reduce the drop-off of the loudness at low frequencies. An example of the improvement in the frequency response when such a passive radiator is installed is shown as plot **24** in FIG. 1. An example of the improvement in the frequency response attributable to the installation of a prior art passive radiator can be understood by reviewing plot **26** in FIG. 2. Note that the drop in the frequency response curve at lower frequencies in plot **26** is very severe before the range of inaudible frequencies **28** is reached. In this configuration, AREA2, the area under the curve to the right of the peak above a minimum loudness level, is larger than AREA1 which is the area under the curve to the left of the peak. This imbalance is indicative of the relative distortion that can be heard as the loudness of the passive radiator nosedives and falls below an audible loudness. The low frequency loudness

and energy are not balanced with the high frequency loudness and energy. The area under the curves provide a measure of the imbalance.

Recent trends in the audio systems market have been leaning towards enhancing the bass or sub-woofer response of the audio reproduction systems, so that even if a sound is below the low limit of the range of audible sound, the sound level is high enough so that the listener, although he or she cannot "hear" the sound with ears, they can "feel" the sound as parts of their body are hit by the low frequency waves. At low frequencies, a limitation of passive radiators has been that the low frequencies require large displacements of the moveable radiator elements. Such large displacements can exceed the available range of motion of moveable radiator elements. For example, in FIGS. 4, 5 and 6, a speaker spider **62** at its perimeter is attached to the back end of a speaker basket **50** while the spider's center edge (or core) it is attached to the back end of a speaker cone **58** or a diaphragm **68** to spider **72** connection element **74**. In each pictured radiator, a central moveable element is suspended by a speaker "surround" (**52**, **70**, **84**) which acts as the flexible element between the stationary front of the speaker basket (**50**, **66**, **80**) and the speaker moveable element. Because the range of travel available from each spider (**62**, **72**, **88**) is less than the range of travel available from the surround (**52**, **70**, **84**), as the spider (**62**, **72**, **88**) reaches the limit of its travel and stops. The sudden stop in the movement of the spider, due to its full extensions, causes distortions in adjacent components as well as in the pressure gradients in the speaker chamber. These distortions can be heard as static and/or unnatural discontinuities in the sound. The ratio of the speaker basket back opening "B" (which supports the spider) to the speaker basket front opening "A" (which supports the surround) is approximately 0.5 (or 50%).

In the instance when a passive radiator constructed solely of a speaker cone is connected only as its peripheral rim to an annular support surface in the wall of a speaker, for example, as shown in the U.S. Pat. No. 4,207,963, to Klasco, a larger range of travel is available to accommodate large movable element displacements experienced at high volume and low frequencies. However, the use of a surround around the perimeter of the top of the cone and the cone shape produces cone wobble which also distorts the sound. The object of the Klasco patent was to arrange active elements to reduce the wobble in the passive radiator.

In the instance where a lone speaker cone suspended in a cavity opening is used, the response of the passive radiator during low frequency cycles as the cone is forced outward and pulled inward can be non-linear as the flexible member (surround) holding the cone tends to have different non-linear force to displacement characteristics when being stretched outwardly as compared to when it is being stretched inwardly.

The limitations on travel as shown in the prior art described in FIGS. 4, 5 and 6 and the wobble of a passive radiator as discussed in the Klasco patent and such a configuration's non-linearity, highlight the shortcomings of the prior art passive radiators.

The spatial requirement of the prior art passive radiators is also a drawback. The prior art passive radiators are quite large and bulky and extend a large distance into any sealed cavity. This spatial requirement must be taken into account when designing features and companion speakers to fit into the sealed cavity.

Recently there has been an increasing demand for loudspeakers for use in a very compact/shallow space. This demand was born by consumer appetite for louder sound

grew couple with the desire for less obtrusive speakers. Recently, home audio consumers have begun a major shift from larger, conventional loudspeakers housed in cabinets that stand alone in the room—to smaller piston speakers that mount within the wall of a house. The available depth in in-wall locations is dictated by the use of 2×4 studs during construction thus creating a space that is less than 4" deep.

This need for shallow, low profile speakers are not limited to meeting the home audio demand. Such low profile speakers also have application in cars, boats, airplanes and other locations that will benefit from the depth reduction without taxing the sound pressure level. In cars for example, the available mounting depth behind the door panel is much less than the minimum height of conventional speakers. In order to use conventional speakers in such locations, it is nearly always necessary to use a raised grill cover over the speaker since it necessary to have a portion of the speaker height extend above the surface of the door panel into the passenger compartment.

For the most part, subwoofer construction has followed conventional technology—the use of an oscillating diaphragm that responds to a varying magnetic field developed by an applied audio signal. That varying magnetic field causes the diaphragm to be attracted and repelled to and from the intermediate position where the diaphragm rests when no audio signal is applied to the speaker. For the most part, current speaker technology uses a loudspeaker made of a rigid diaphragm, or “cone”, suspended within a speaker frame, or “basket” around the outer edge with a flexible membrane, or “surround”. This membrane allows the cone to move inward and outward when driven by a varying magnetic field resulting from the application of an audio, or “music”, signal applied to the speaker.

Over the years speakers have been designed with a conventional structure—a cone connected to the outer part to a speaker frame, or basket, through a flexible membrane (surround). To develop a back-pressure wave and to control axial movement of the cone, designer installed a secondary part called a “spider” that also connects the inner part of the cone to the speaker frame. Almost all spider materials used are made of cloth that has been treated and pressed in a heated die to form the shape of the spider that was sought. Conventional speakers require a huge mounting depth that render them useless in shallow spaces where consumers now wish to place speakers. For example, a conventional 10" diameter speaker, with an excursion of +/-1" requires a mounting depth of at least 7". Moreover 12" diameter conventional speakers requires a mounting depth of at least 7" to 8". Hence conventional speakers clearly will not fit in shallow spaces, such as walls where the mounting depth is limited to about 3.5", or less, unless a smaller diameter conventional speaker is used. Thus, consumer demand has created a need that conventional speakers can not meet and still provide the performance desired by the consumer. Therefore there is a need to develop loudspeakers that have a large piston area with a minimum mounting depth. Low profile speakers designed using the present invention meet that need.

Conventional speakers have many weaknesses that have become much more evident in longer stroke woofers. Since conventional speakers rely upon the glue ring connection of the cone with the voice coil bobbin and spider, that connection is subjected to bending moments that collapse the glue ring during downward (inner stroke movements) and flare outward the glue ring during outward strokes. Additionally, the structure of conventional speakers promotes harmonically related bending of the cone during inward/outward

strokes that fatigues the inner portion of the cone and leads into what is known as a neck-cone failure. This typically, partially or completely, breaks the cone into two cones around the neck area. Prior to that type of failure the cone is known to have a cycle per life during which the cone is breaking down and during the slow breakdown of the cone, the conventional promotes increasing distortion that is increasingly unpleasant for the listener. Further conventional speakers have not been designed to maintain the inner suspension (spider) parallel to the outer suspension (surround) as the cone is driven by the voice coil. The spider and surround are each rigidly connected to the inner and outer edges of the cone, respectively, and any misalignment of those connections and/or variations in the material of the spider, surround and cone around the speaker cause the cone to twist in opposite directions as it is driven inward and outward, with the amount of that twisting increasing as the stroke of the voice coil bobbin increases in each direction. This connection configuration can only connection can only compromise such a structure this as the cone bends as it is moves and causes the twisting, or spiraling movement.

Another problem that results in reduced audio performance of conventional speakers is wobble of the voice coil during operation of the speaker. Current speaker design structures suffer from several compromising parts that play a major role in producing a high level of harmonic distortion. As it has been a trend in speaker design to get the most output out of a speaker opening, they resort to increasing the excursion in order to increase the amount air displacement. What previously was a 0.3" high voice coil are now 1.5" and as high as 2" winding heights of the voice coils. These increased height voice coils thus move in excess of 1" each way, inward and outward. Often speakers can be found where the movement is as much as 1.5" each way. During extreme excursions, these woofers are pushed by these long voice coils that weigh three times as much as in previous designs. The motor (voice coil) is connected to the cone and the spider in what is known as the inner suspension.

The cone is the stiff component relative to the suspension and surround, extending outward (generally) and connects the inner suspension to an outer larger diameter suspension. The combination of spider, cone, outer surround, and voice coil bobbin are interconnected to oscillate axially. When an audio signal with a frequency F is sent to the voice coil it develops a variable magnetic field that interacts with the fixed magnetic field produced by the magnet assembly to produce an oscillating force. During these oscillations, the moving parts are subjected to a uniform internal pressure due to the compressed air in the enclosure and tension developed by the spider and surround. The spider and surround each have some manufacturing offset that tend to be apparent during long strokes as the moving elements will start to wobble. The cone typically is made of processed materials (e.g., pressed paper) thus the cone also possesses a non linear stiffness that leads to another offset. The combination of these offsets leads to wobble of the voice coil bobbin.

That wobble can distort the sound produced in varying degrees as the voice coil travels inward and outward in many ways, e.g., distorting the shape of the cone. Wobble can also reduce the useful life of a speaker by repeatedly over stressing the cone and other components that eventually results in failure of the component, e.g., a crack or a tear in the cone, partial separation of the cone and surround, etc. Wobble can even result in total failure of the speaker. This can occur if the voice coil is over driven outward with the lower edge of the voice coil bobbin coming completely out

5

of the magnet assembly with the wobble shifting the lower edge of the voice coil bobbin so that it is no longer aligned with the slot in the magnet assembly. The bottom edge of the voice coil bobbin then hangs up on the top of the magnet assembly as the tension in the spider and surround pull the cone and attached voice coil bobbin downward when the lower end of the voice coil bobbin does not reenter the magnet assembly. Once hung up on the top of the magnet assembly the speaker can no longer move regardless of whatever drive signal is applied to the voice coil since the voice coil is no longer in the magnetic field of the magnet assembly so the drive signal does not interact with the magnetic field, i.e., no signal when applied to the voice coil will be able to move the voice coil bobbin.

SUMMARY OF THE INVENTION

An aspect of the present invention provides an embodiment that provides a symmetrically loaded, shallow suspension speaker. In the speaker embodiments of the present invention, the symmetrically loaded, shallow suspension supports a substantially stiff diaphragm that functions similarly to the "cone" of the prior art. In the present invention the diaphragm, or cone, is made of a material such as honeycomb, thin aluminum, and other composite and non-composite light-weight materials; conventional cone materials will not work in this application since the diaphragm is substantially flat and light-weight. This flat diaphragm is suspended by the outermost edge with a suspension system that is entirely outside the diameter of the magnet, thus allowing the suspension to extend to nearly the bottom of the speaker basket on the maximum inward excursion of the voice coil and diaphragm. Thus, the suspension operational depth is not the limiting factor of the speaker basket design and the actual mounting depth of the speaker. Note that mounting depth and cone wobble control are interrelated in the speakers of the present invention; the closer the outer portion of the suspension is to an inner one, the chance of wobble increases as the the mounting depth of the speaker becomes shallower. As will be seen below in the detailed description of the various embodiments of the present invention, the elements of the suspension system of the present invention have been designed maximize the spacing between the inner and outer portions of the suspension system, thus minimizing the possibility of wobble in the low profile speakers of the present invention.

The various embodiments of the present invention permit the designer to maximize air movement in a given mounting depth with a configuration that optimizes the operation of the moving parts (i.e., diaphragm, suspension and voice coil) in the electromagnetic environment that complements the fixed mechanical structural configuration of the non-moving parts. In one embodiment, this invention allows the designer to have an over excursion (outward/inward limiter) that is optimized with the available mounting depth. For example, the present invention allows the designer to have a 15" diameter speaker that fits in a mounting depth of as little as 3.5" with a diaphragm excursion of approximately ± 1 ", while a conventional speaker with the same size working piston requires a mounting depth of 6" to 7".

The present invention also includes several embodiments that allow the user of the speaker to replace the voice coil, or the voice coil and the cone or diaphragm, should they become damaged. This would be an attractive option for performers that have a speaker fail during a performance when a speaker is over-driven or dropped.

6

Yet another embodiment of the present invention provides a speaker that is designed to substantially eliminate wobble of the voice coil during operation, and thus remove that source of distortion and early failure of the speaker. This is accomplished with the creation of triangular ring that extends upward from the top edge of the voice coil bobbin with that ring mating with a flat diaphragm at a right angle directly above the top edge of the bobbin. The outer edge of the diaphragm connects to the inner edge of the surround at the point where a sloping side of the "triangle" is also connected and slopes down to the top edge of the bobbin where the opposite end is connected. The outer portion of the diaphragm provides the third side of the triangle.

BRIEF DESCRIPTION OF THE DRAWINGS

FIG. 1 is a plot of frequency response versus sound level in decibels showing the response of a sealed speaker box and a conventional droned tuned speaker box;

FIG. 2 is a frequency response graph showing the plot of the frequency response contribution from a passive radiator to the total tuned response in a speaker box system;

FIG. 3 is a frequency curve showing a plot of the frequency response using a device according to the present invention;

FIG. 4 is across sectional view of the prior art passive radiator supporting masses at both the base of the cone and on a diaphragm spanning the large opening of the cone at the base of the speaker;

FIG. 5 is a cross-sectional view of a prior art passive radiator showing a moveable diaphragm connected to a speaker surround at the mouth of the speaker basket to a speaker spider at the back of the speaker basket;

FIG. 6 shows a cross-section of a prior art passive radiator showing a speaker cone with a tuning mask at its base connected to the spider to the speaker basket at its narrow end connected through a surround to its wide end of the speaker basket;

FIG. 7 shows an isometric cut away view of a configuration according to the invention;

FIG. 8 shows a cross-sectional view of a diaphragm plate fixed to a surround which in turn is fixed to an external ring. Prior to their assembly into a configuration according to the present invention;

FIG. 9 shows a configuration according to the present invention fixed in a speaker wall;

FIG. 10 shows a configuration according to the invention where the two diaphragm plates are fixed one to the other;

FIG. 11 shows an alternate configuration according to the invention where the arches of the speaker surround project in the same direction;

FIGS. 12, 13 and 14 show cross sectional views of several alternate embodiments according to the invention, where the wall of the speaker cabinet is used as the flat central core member of the passive radiator in a speaker system;

FIGS. 15, 16 and 17 show a schematic cross sectional configuration where the embodiment of FIG. 9 has been modified and configured with features which enhance in several different ways the passive speaker design;

FIG. 18 shows a perspective view of a passive speaker according to the invention incorporating frame vent holes as one aspect of the invention;

FIG. 19 shows a cross sectional perspective view of a frame side vent holed configuration as shown in FIG. 18;

FIG. 20 shows a perspective view of a passive speaker according to the invention incorporating surround openings (slits) as vent holes as one aspect of the invention;

FIG. 21 shows a schematic cross sectional view of a speaker box utilizing a passive speaker design according to the invention;

FIG. 22 shows a schematic cross sectional view of a speaker box utilizing a passive speaker with through the frame vent holes in a design according to the invention;

FIG. 23 shows a schematic cross sectional view of a speaker box utilizing a passive speaker with through the surround vent holes communicating with the inside of the speaker box enclosure in a design according to the invention;

FIG. 24 shows a schematic cross sectional view of a speaker box utilizing a passive speaker with through the surround vent holes communicating with the outside of the speaker box enclosure in a design according to the invention;

FIG. 25 shows plots of surround extension versus force for several configurations (as shown in FIGS. 25A, 25B and 25C) of large displacement passive radiators to show a comparison of generalized behavior when the progressive roll embodiment of the present design is compared with several alternatives;

FIG. 25A shows a cross sectional view of one elastic membrane of a set of two which support a mass from a frame for a passive speaker, the design includes two examples of using one large roll to span a large gap to provide a large stroke for the vibrating mass;

FIG. 25B shows across sectional view of one elastic membrane of a set of two which support a mass from a frame for a low profile passive speaker, the design includes three surround rolls having substantially equal roll diameter;

FIG. 25C shows a cross sectional view of one elastic membrane of a set of two which support a mass from a frame for a low profile passive speaker, the design includes three surround rolls utilizing progressively smaller surround roll diameters as the elastic membrane moves from the perimeter frame to the center mass;

FIGS. 26A and 26B show cross sectional schematic views of the single surround large gap arrangement as shown in FIG. 25A, the relaxed state is shown in FIG. 26A and a nearly-fully extended state is shown in FIG. 26B;

FIGS. 27A and 27B show cross sectional schematic views of the three equally sized roll diameter surround arrangement as shown in FIG. 25B, the relaxed state is shown in FIG. 27A and a nearly fully extended state is shown in FIG. 27B;

FIGS. 28, 28A, 28B and 28C show cross sectional schematic views of the three progressively sized roll diameter surround arrangements as shown in FIG. 25C and according to the invention, the relaxed state is shown in FIG. 28 and a nearly fully extended state is shown in FIG. 28C, a state where substantially only the outer surround roll is extended is shown in FIG. 28A, and a state where the outer surround roll and middle surround roll are substantially fully extended is shown in FIG. 28B;

FIG. 29 shows a cross sectional schematic view according to the invention where three progressively sized surrounds contact each other at their saddles;

FIG. 30 shows a view of FIG. 29 with the addition of vent features for a device according to the invention;

FIG. 31 shows a cross sectional schematic view according to the invention where three progressively sized surrounds are separated from each other at their saddles by spacers which maintain the distance between saddles;

FIG. 32 shows a view of FIG. 31 with the addition of vent features for a device according to the invention;

FIG. 33 shows a perspective view of a passive radiator incorporating three progressively sized surrounds as pictured in cross section in earlier Figures;

FIG. 34 a perspective view of a sound transducer system (speaker system) contained in a tube enclosure;

FIG. 35 is a schematic cross sectional view of the tube enclosure for the speaker system of FIG. 34, with an active element at one end and a passive element at the other end, the tube is made of aluminum, and may have fins to assist in cooling;

FIG. 36 show a first embodiment low profile, overhung, shallow speaker design in cross-section with FIG. 36A in the unexcited position, FIG. 36B in the maximum outward excursion position, and FIG. 36C in the maximum inward excursion position;

FIG. 37 show a second embodiment low profile, overhung, shallow speaker design in cross-section with FIG. 37A in the unexcited position, FIG. 37B in the maximum outward excursion position, and FIG. 37C in the maximum inward excursion position;

FIG. 38 show a third embodiment low profile, overhung, shallow speaker design in cross-section with FIG. 38A in the unexcited position, FIG. 38B in the maximum outward excursion position, and FIG. 38C in the maximum inward excursion position;

FIG. 39 shows the embodiment of FIG. 36A with a modified suspension;

FIG. 40 shows the embodiment of FIG. 36A with a second modified suspension and a modified diaphragm configuration;

FIG. 41 show the embodiment of FIG. 36 with a third modified suspension and a second modified diaphragm configuration with FIG. 41A in the unexcited position, FIG. 41B in the maximum outward excursion position, and FIG. 41C in the maximum inward excursion position;

FIG. 42 show a first embodiment low profile, underhung, shallow speaker design in cross-section with FIG. 42A in the unexcited position, FIG. 42B in the maximum outward excursion position, and FIG. 42C in the maximum inward excursion position;

FIG. 43 show a second embodiment low profile, underhung, shallow speaker design in cross-section with FIG. 43A in the unexcited position, FIG. 43B in the maximum outward excursion position, and FIG. 43C in the maximum inward excursion position;

FIG. 44 show an attachment mechanism for the replaceable voice coil of FIG. 45 with FIG. 44A being an exploded, perspective view of the voice coil attachment components and FIG. 44B being a perspective view showing the screw type conductors of FIG. 44A in a joined position;

FIG. 45 show a first embodiment low profile, shallow speaker design in cross-section having a replaceable voice coil with FIG. 45A showing the voice coil external to the remainder of the speaker, and FIG. 45B showing the voice coil installed in the speaker;

FIG. 46 show in cross-section a speaker in a conventional configuration with a replaceable cone and voice coil with FIG. 46A showing the cone removed and the details for attachment of the cone and voice coil to the remainder of the speaker, and FIG. 46B shows the fully assembled speaker;

FIG. 47 shows, in cross-section, or a center slice of, a convention speaker with the spider connected to the top edge of the voice coil bobbin (cross-hatching has been omitted to minimize confusion);

FIG. 48A shows, in cross-section, or a center-slice of, another embodiment of a speaker of the present invention that minimizes wobble of the voice coil bobbin during excursions during use that is easily assembled (cross-hatching has been omitted to minimize confusion);

FIG. 48B is a partial view of the speaker of FIG. 48A to illustrate the details of various items of the speaker and how they attach to the top edge of the voice coil bobbin;

FIG. 49A is the conventional speaker of FIG. 47 with the voice coil drawn inward to the position of the maximum stroke with the bending forces shown on the cone and bobbin;

FIG. 49B is the conventional speaker of FIG. 47 with the voice coil driven outward to the position of the maximum stroke with the bending forces shown on the cone and bobbin;

FIG. 50A is the sub-zero speaker of FIG. 48A with the voice coil drawn inward to the position of the maximum stroke illustrating the cancellation of the forces exerted on the various components of the speaker;

FIG. 50B is the sub-zero speaker of FIG. 48A with the voice coil driven outward to the position of the maximum stroke illustrating the cancellation of the forces exerted on the various components of the speaker; and

FIG. 51 is low profile version of the speaker of FIG. 48A with the lateral support diaphragm in position just prior to attachment to the top edge of the voice coil bobbin and the cone.

DETAILED DESCRIPTION

An embodiment according to the invention is shown in FIG. 7. A speaker box which acts as an integral speaker support ring 100 is a circular opening in a speaker box. To the speaker box at one edge of its wall is attached an inner surround 114 which has at its inner perimeter an inner diaphragm 106. At the outer wall of the speaker box 100, an outer surround 118 is attached with its inner perimeter fixed to an outer diaphragm 110. A connecting member (or mass) 124 is fixed between the two diaphragms 106, 110 so that the two move together in parallel as the sound pressure due to the frequencies in the sealed box causes the displacement of the two diaphragms simultaneous and in parallel. The inner and outer surrounds 114, 118 are configured so that the arch of 108 of the inner surround projects inwardly while the arch 120 of the outer surround 118 projects outwardly. In short, the center diaphragms 106, 110 and connection member 124 are supported only by the surrounds 114, 118 and the arches 108, 120 of the surrounds project in opposite directions.

In a normal speaker configuration where only one surround is used. e.g., at the perimeter of a speaker cone, there is a non-linear characteristic in the restoring force relative to displacement for a normal half circle type surround. The restoring force is the force that restores the speaker assembly to its neutral position for example during transportation and/or when the speaker is not in use. The non-linearity of the stressing of the inside surface of the arch versus the outside surface of the arch as the surround is stretch by the displacement of a center disk or speaker cone creates a small but detectable distortion. In such arrangements increased air pressure due to the sound waves does not move the diaphragm at the same rate when subject to similar pressure gradients, but rather the air starts to become compressed and generate reflected pulses as a result of the non-movement or slower movement of the diaphragm due to the different displacement rates. As the diaphragm in the passive radiator is exposed to air pressure due to sound volume, the use of two oppositely facing surrounds provide an effective compromise and an improvement over the use of the single surround by providing an approximately linear pressure to displacement relationship irrespective of whether a sound

wave is positive (for example, causing the diaphragm to move out) or negative (for example, causing the diaphragm to move inward).

The use of two oppositely facing surrounds which are fixed to each other and with virtually no separation, for example, as shown in FIG. 10 provide a benefit over the prior art in that the spring constant in the full range of travel from the extreme negative through the neutral (or balanced condition) position to the extreme positive is much closer to linear than when using a single surround alone. However, in the configuration of FIG. 10, wobbling (defined as non-uniform displacement of the diaphragm) of the surround around its perimeter, for example, if a sound pressure wave were to come not perpendicularly into the diaphragm but at an acute angle from one side, then one side of the diaphragm could be preferentially displaced more than the other side at least momentarily this wobble could cause an undesired reflective wave and sound interference which is out of phase with the primary frequency. However, in instances where such a passive radiator is mounted directly opposite a single driver or a group of generally symmetrically arranged drivers, e.g., as in the Klasco patent discussed above, the configuration of FIG. 10 provides a noticeable if not distinct advantage over configurations where only a single surround using a speaker cone is used. Further, the flat surface of the diaphragm provides no transverse surface against which a transverse component of a pressure wave vector could cause lateral translation of the diaphragm as it could in the prior art where the speaker cone provides a substantial laterally extending surface, which accentuates any wobble that is experienced.

A configuration according to the present invention has the additional advantage of eliminating the wobble problem by the use of a parallelogram-type parallel link arrangement where the two diaphragms 106, 110 each have their perimeters act as two ends of a fixed link of a parallelogram type linkage. A second set of fixed links are the corresponding inner and outer walls to which the outside perimeter of the surrounds 114, 118 are fixed. The moveable links connecting the two fixed links are the surrounds which extend between the perimeter of the central diaphragm 106, 110 and the inner perimeter of the outer ring for example, 134 in FIG. 9. Using this configuration will reduce any wobble by creating additional resistance to a wobbling effect due to the two surrounds being mounted in parallel at the end of what effectively amounts to an elastically extendible pivoting lever arm. Thus any configuration according to the invention for example as shown in FIG. 9, where a 45 degree sound wave coming into the central diaphragm would be resisted by both sets of surrounds such that predominately linear motion perpendicular to the face of the diaphragms would occur. The motion of the central diaphragm assembly while not completely limited to a linear back and forth motions is severely constrained to move easily only back and forth perpendicular to the diaphragms 106, 110 absent a strong transverse force vector. Similarly, the flat face of the diaphragm rigidly resists pressure pulses having force vectors which are parallel to its face, while it is very easily movable in a direction perpendicular to its face when impacted by sound pulses having force vectors with directional components perpendicular to the face of the diaphragm. In this way, an improved passive radiator can be constructed and used. While in the Figures shown, the ratio of the inner and outer diaphragm support openings are substantially equal, (i.e., they have a ratio of approximately 1), it is possible to construct passive radiators according to the invention where the ratio of the smaller diaphragm connection opening to the

larger diaphragm connection opening is approximately 0.8 or greater (e.g., distance "C" on one side of the opening will be different than the distance "D" by a ratio of the smaller to the larger of 0.8).

The construction of the passive radiator is quite simple as shown in FIGS. 7, 8, 9, 10 and 11. The outside edge of the surrounds can be fixed directly to a sealed cavity or can be fixed to a surround support ring 134 which in turn is then fixed to a speaker enclosure wall 130. Some combination of elements to hold the outer ring and allow the center to move freely from its neutral position must be found.

An alternative configuration using a series of surrounds 142, 144 provides that the arches of 146, 148 such surround must extend in a single direction. This configuration while not optimum does provide the advantage over the prior art of eliminating or substantially eliminating the wobble problem referred to earlier. In a configuration as shown, the spring constants will be unequal and the non-linearity of the spring constant plot will be attenuated by the use of two surrounds whose spring constants add to exacerbate their distortion from linear.

FIG. 12 shows an alternate embodiment according to the invention, a speaker cabinet wall 150, initially one piece, has circular slot routed into it thus separating a centerpiece 152 from the speaker cabinet wall 150. The round centerpiece 152 is centered in the opening of the cabinet wall and a wide contoured bead of filler material (e.g., silicon rubber) is run between the inside of the outer opening of the wall and the outside of the centerpiece 152. The cross sectional shape of the filler material is such that it retains an elastic character once cured. The cross section shown is commonly found in elastic seals between building joints where substantial movement is expected.

FIG. 13 pictures a spider type elastic member 160 having been placed between the centerpiece 152 and the speaker cabinet wall 150, as described for FIG. 12 above.

FIG. 14 pictures an alternate embodiment where a set of two surrounds 170, 172, provide the elastic connection between the speaker cabinet wall 150 and the centerpiece 152. While a round shape is preferred, the use of a less efficient shape is in accordance with the invention, for example a polygon or a compound curve shape may be used. A centerpiece thickness in excess of 0.25 inches is preferable to help maintain a linear movement and reduce or eliminate any wobble that may occur.

A review of the plot as shown in FIG. 3 shows that the frequency response of a tuned passive radiator according to the invention extends the usable frequency range from the low audible to the inaudible range of frequencies. All audible frequencies can be heard and the inaudible frequencies for example, an earth shake or pounding can be generated by such speakers so that the user can "feel" the vibration as the user's surroundings susceptible to such low frequency waves start to vibrate. The use of such speaker enhancing device is very attractive to sophisticated users as well as the general public in viewing many action movies that feature such low frequency sounds.

An aspect of the present invention further enhances the sound performance. The closure of spaces between opposing surround rolls can cause a high pressure secondary cabinet that slows down the response. A pressure relief system is provided to allow the air trapped between two diaphragms to have the same pressure as that in the speaker box (or alternately outside the speaker box) via port holes that are large enough to keep the air speed through these holes under 1% of the speed of sound with a value of about 12 ft/second. Since these numbers are worse at the passive resonance

frequency, this calculation can be optimized for the maximum excursion calculation. The pressure relief port can be implemented best through holes in the inner surround that leak air directly into the speaker box.

FIGS. 15, 16 and 17 show several ways that an air vent (pressure relief system) according to the invention can be implemented. FIG. 15 shows in cross section vent holes 176 disposed to provide one or more passages from the air space between the center mass 178, the outer elastic member (surround) 180, the inner elastic member (surround) 182, and the outside frame 184, which can form a pressurizable chamber, through the frame 184. These same holes 176 are shown in the perspective view of FIG. 18 and again in the cross sectional perspective view of FIG. 19. In the schematic views in particular, it appears that the holes 176, in use, are situated to be nearly sealed against the surrounding wall hole opening of the speaker box in which the passive radiator might be mounted. To operate without noise and undue damping there must be a space between the hole of the speaker box in which such a configuration is mounted and the perimeter of the radiator frame 184 facing it, so that air can pass freely at speeds below 2% of the speed of sound.

FIG. 16 shows a schematic cross sectional view of an alternate configuration for maintaining parallelism as the center mass moves back and forth due to speaker box pressures while still providing for improved response and large travel due to a pressure extremes. A series of holes (or slits) 190 are disposed approximately equally spaced around the annular ring of the inside surround 182. The holes 190 in this configuration are open to the inside of a speaker box and act as a vent to prevent the build up of pressure in the surround contained air space 194. In this configuration an outside frame flange 192 is solid.

FIG. 17 shows a schematic cross sectional view similar to the configuration shown in FIG. 16. In this embodiment there are a series of holes (or slits) 198 which are disposed approximately equally around the annular ring of the outside surround 180. The configuration of these holes 198 is also shown in FIG. 20, which shows a perspective view of this configuration. The holes 198 in this configuration are open to the outside of a speaker box and act as a vent to prevent the buildup of pressure in the surround contained air space 198.

FIG. 19 shows the passive radiator relationship to its mounting to a speaker box opening 210. In this configuration the outside frame 184 has two flanges, one smaller in diameter (which fits into the speaker box opening 210) and a second one that is larger in diameter that seals to the surface around the speaker box opening.

FIGS. 21, 22, 23 and 24 show arrangements of a speaker (high pressure box) box containing a driver (speaker) 213 and an amplifier frame with amplifier circuitry 215 fixed to the speaker box 217 (in these instances the frame is sealed to an opening of said speaker box with heat sink elements of the amplifier outside the box). Each of these speaker boxes includes an opening for receiving a passive radiator according to the invention. Passive radiators as shown and described in FIGS. 9, 15, 16 and 17 are shown positioned in the passive radiator opening of the speaker box as pictured in FIGS. 21, 22, 23 and 24, respectively.

Progressive Surround Roll Radiator Construction

An aspect of the present invention that utilizes low profile large stroke passive radiators includes the use of a progressive roll system that further enhances the performance of passive radiator design.

Low frequency instruments emanate sound waves via vibration of diaphragms. These diaphragms oscillate at a low frequency. The oscillations have maximum amplitude in the center of the diaphragm with a proportionally reduced oscillation across the diaphragm with no oscillatory motion at the diaphragm frame. The dynamic oscillatory activity associated with a bass drum is useful in illustrating the dynamic relationship between the oscillating diaphragm and the emanating sound wave.

When a drummer strikes the center of the bass drum, the striking force bends the diaphragm inward such that the diaphragm shape is no longer flat, but is deformed in an approximation of a cone or sphere. The pressure inside the drum increases and is transferred to the other side of the drum, and results in an outward movement of the diaphragm. The tension and the phase angle of the sound wave as they bounce back and forth allow the signal to decay in a harmonic fashion. The decay time is directly related to the diaphragm diameter, tension and the distance between the two diaphragms at any fixed frequency. Utilizing the apparatus and methods according to the invention provides that opportunity to approach a bass drum sound when using relatively smaller 12" and 15" speakers. To approach the desired condition the passive radiator is matched with the speaker has to be tuned low enough and has to move out axially to produce the same air movement, i.e., SPL at any given frequency is strictly related to the quantity of air moved at that frequency. The quality of sound must also be maintained. The quality of sound is measured by the group delay. A group delay is the time versus frequency curve that describe the response time delay at any given frequency. A 20 ms delay at 20 Hz is said to be audible distortion. Group delay is directly proportional to the diaphragm excursion. A long excursion creates long group delays.

One example of a surround structure used in a speaker is to use a single large, surround, a cross section of which is pictured in FIG. 25A. The single surround provides a large axial stroke and an even larger stroke if an elliptical cross section (as shown by the solid line) as opposed to the circular cross section (as shown by the dashed line) is used. While this configuration has a good potential for large axial movements, the large roll diameter allows side to side instability at even small increments of axial excursion. A plot of relative excursion versus relative force for an approximation of an elliptical surround configuration is shown as curve 212 as pictured in FIG. 25. The restoring force is relatively small at small axial displacements (extensions) and rises rapidly as the extension increases.

A second example of a surround structure is the use of what are known as an "m" surround (two or more side by side surrounds). FIG. 25B shows such a structure where three smaller roll diameter surrounds are joined in a concentric circle pattern with the intent to achieve a large excursion—like the one shown for the single surround of FIG. 25A—with a lower profile. A plot of relative excursion versus relative force for an approximation of the three side by side surround arrangement is shown by the plot 214 shown in FIG. 4. The restoring force at low excursion (extension) dimensions is greater than that for a single elliptical surround as shown in FIG. 25A.

A set of cross sectional views of a passive speaker arrangement using the single large surround and the three small surrounds (of FIGS. 25A and 25B) in a relaxed state is shown in FIGS. 26A and 27A, respectively, and in their fully extended state in FIGS. 26B and 27B, respectively. What is noteworthy about reviewing these passive radiator arrangements is that while their relative force versus exten-

sion curves are relatively straightforward (though non-linear) and similar, the excursion in the axial direction of motion is distributed substantially uniformly over the whole span of the gap between the centerpiece (220 or 221) and the outer frame 224. This uniform distribution of the strain (extension or excursion) correlates to a lateral (side to side) instability (wobble) of the centerpieces even at small excursions associated with small sound pressure levels. And any instability introduced at small excursions is amplified as the magnitude of the excursion increases.

To optimize an apparatus according to the present invention large qualities of air must be moved, but using the shortest most even diaphragm possible, like a bass drum. The diaphragm movement must decay uniformly at the side, i.e., as the diaphragm approaches the stationary frame. The movements must be axial and not side to side as such movements will cause a wobble that produces audible distortion.

An embodiment according to the invention which overcomes the drawbacks of the previously discussed arrangements, is to use a progressive roll diameter configuration, for example a cross section of which is shown in FIG. 25C. In this arrangement a set of three surrounds are provided, the outer surround being the largest, with surrounds internal to the outer one being progressively smaller. This arrangement provides a non uniform position specific extension characteristic, an approximation of which is shown by the curve 216 in FIG. 25. An understanding of the localized position based extension of the progressive surround arrangement can be understood by correlating the plot of the curve 216 in FIG. 25 with the relative movement of the centerpiece and surround portions as shown in FIGS. 28, 28A, 28B and 28C. A relaxed unextended condition of a passive radiator is shown in FIG. 28, where dashed line 230 correlates to the centerline of the frame and centerpiece 232 in an at rest condition and where line 234 provides a relative position reference for the position of the middle surround 236. In FIG. 25 this condition is represented by the origin (position 0,0). When a first level excursion (extension) takes place as is shown in FIG. 28A, the interrelationship of the overall stiffnesses of the three adjacent surrounds causes the perimeter surround 238 to be stretched to its travel limit at a first correlative rate, while the middle surround 236 and the inner surround 240, are stretched very little and almost not at all, respectively. The first correlative rate, might be considered to be an approximation of a spring constant which correlates to the movement of the centerpiece 232 from its at rest position to be displaced a distance 242 which shows that the movement of the centerpiece is due to the extension of the outer surround 238. The displacement of the centerpiece to this first level correlates to the portion of the curve 216 that goes from the origin to a corner of the curve identified adjacent a vertical reference line 244 on FIG. 25. If the total available travel of the centerpiece is identified as being 100% which correlates to 1.0 in this example, then it can be seen from FIG. 25 that the relative travel due to extension of primarily the outer surround exceeds 60% of the total available travel. Thus all small excursions and even moderately sized excursions of the centerpiece occur at the outer perimeter of the structure in the outer surround thus providing a localized position based extension. The distance 242 shown in FIG. 28A correlates approximately to the curve position associated with the reference line 244.

In FIG. 28A, reference line 246 correlates to the position of the inner surround 240 at the first level extension shown in FIG. 28A.

FIG. 28B shows a second level extension of the centerpiece 232 of the passive radiator. In this condition, the outer surround 238 which had formerly been stretched to the limit of its travel, stretches no more. The additional travel of the centerpiece, through a distance 248, occurs primarily by stretching of the middle surround 236, with very little stretching of the stiff inner surround 240. The increased force needed to stretch the middle surround (stiffness) causes the curve 216 relating to the movement of the centerpiece to turn a corner (at 244) and move at an increased rate upward to a curve position correlating to the reference line 250 on FIG. 25. At this position, the middle surround 236 has reached the limit of its travel. A reference line 252 corresponding to the vertical position of the bottom of the centerpiece 232 at this second level position is identified in FIG. 28B.

FIG. 28C shows the fully extended third level position of the centerpiece 232 showing the vertical travel distance over the second level position as shown in FIG. 28B. To reach this position, since both the outer 238 and middle 236 surrounds had reached the limits of their travel only the inner surround is subject to stretching. This stretching occurs over the distance 254, which correlates to the portion of the curve 216 to the right of the reference line 250. Curve 216 again turns a corner (at 250) and requires a markedly increased rate of force versus extension to achieve full travel. The result being that while the general overall characteristics of the progressive roll configuration exhibits a similar overall appearance, the actual performance due to the localized position based extension substantially reduces the chance that wobble (as sound distortion) will be heard at low sound pressure levels without unduly limiting the ability of the passive resonator to resonate at relatively high sound pressure levels without audible distortion which results in improved sound quality.

As shown in the FIG. 28 series, vent opening between adjacent surround compartments allows for pressure equalization and/or venting. Several other configurations will be discussed below.

The sizing of the surrounds closest to the perimeter compared with the surrounds positioned closer to the center of the vibrating element depends on two important considerations:

1. Linear stiffness where by the closest to the perimeter (next to the frame) surround will approach maximum excursion just as the range of excursion for the next adjacent surround begins a larger relative motion. This is necessary to produce a distortion free response. If this is not respected a harmonic distortion will overwhelm the fundamental signal and will create a complex signal out of a single tone.

2. The outer roll diameter, whereby the piston diameters relates to the amount of movement for a particular piston and roll diameter. Also the second (inside the outer) roll diameter and the second piston diameter are related in a similar way. Furthermore the outer roll diameter and the inner roll diameter are related to each other in a proportional way such that the outer roll is larger than the inner one following the arc of sphere or a cone (e.g., the inner is no greater than 80% of the diameter of the immediately adjacent outer roll diameter). Once the outer diaphragm diameter (D_o —diameter outer) is selected (see FIG. 25C) and a maximum excursion distance associated with the outer piston (the diameter to the outside of the selected surround) is selected and the configuration of the progressive roll arrangement is set. Since the maximum axis travel equates to approximately 70% of the corresponding roll diameter (d_{ro} —diameter roll outer) a ratio of (D_o/d_{ro}) the roll diameter is set and the

distance to the next diaphragm inside the outer one is set, approximately correlating to D_o minus d_{ro} . Using the three surround example, the middle surround has a piston diameter (D_m —diameter middle) and a corresponding roll diameter (d_{rm} —diameter roll middle) such that the ratio (D_o/d_{ro})= (D_m/d_{rm}) holds true as surrounds progressively get smaller toward the center. These ratios of geometric quantities in practice are dependent on material properties and transitional variations and thus are approximately equal rather than being exactly so. There will be an optimum value for the next roll diameter based on the air quantity moved and speed (i.e., surround stiffness).

FIG. 29 shows a schematic cross sectional view of an embodiment of a progressive passive roll according to the invention where surrounds symmetrically mounted in opposing directions are connected by a series of smooth release transitions 256, 258, 260 to avoid material concentration and the elongation discontinuities associated with stresses and strains through such material concentrations.

During long strokes, the air trapped between the diaphragms can have a high pressure secondary cabinet that slows down the response. To eliminate this problem, air ventilation holes are made in the inside diaphragm (similar to that described above). The ventilation holes must have enough window area to allow air to pass at a speed of no more than 12 ft/sec (approximately 1% of the speed of sound). These holes must be symmetrical so that they do not pose a bias to the surrounds. FIG. 30 shows the configuration as shown in FIG. 29 modified to have vent openings 262, 264, 266 through a face of the several surrounds, similar to that described above for the single surround arrangement (e.g., FIG. 20).

FIG. 31 shows a schematic cross sectional diagram of a progressive roll arrangement, as previously described, where the centerpiece and frame vertical thickness are greater to reduce the chance of sideways motion and the related distortion. To prevent collapse (buckling) of the surround elements, a series of vertical spacers 268, 270, comprising vertical cylinders mating the valley bottoms between surround roll peaks together are provided. These spacers 268,270 can be a thin Mylar sheet or other comparable material whose effect is only to keep the corresponding connections on the upper and lower surrounds at equidistant to one another. In general it is preferred to have the spacer be so lightweight that the oscillatory reaction of the surrounds is unchanged from what they would be without the spacer, except that our of phase and collapse conditions are avoided.

FIG. 32 provides a vented configuration of the embodiment as shown in FIG. 31. The vents are holes 272, 274 through the wall of the spacers 268, 270 with a set of perimeter flange holes 276 providing surface area to allow air movement without generating audible notice of the movement.

FIG. 33 presents a physical realization of the embodiment of FIG. 32. The perimeter flange holes 276 are shown distributed around the perimeter flange and the progressive surround roll diameters 278, 280, 282, correlating to these structures in FIG. 32 are illustrated.

Tube Arrangement

Another configuration according to the invention, showing a speaker and a passive radiator in an enclosure is shown in FIGS. 34 and 35. A speaker enclosure, not unlike the speaker boxes of FIGS. 21, 22, 23 and 24, is specially configured in a tube shape. A 35 driver (speaker) 312 at one end and a passive radiator 314 according to the invention at

the other end. Passive radiators as shown and described in FIGS. 9, 15, 16, 17, 29, 30, 31, 32 and 33 can be used. One of the biggest reasons for failure of voice coils of speakers is embrittlement and insulation breakdown due to high temperatures. In a closed box system where there is no transfer of air between the inside and outside, thermal energy is not dissipated quickly. In the present configuration the tube 316 containing the speaker and driver is made of aluminum and made be fitted with perimeter ribs 318 to enhance cooling. Measurements have shown that the temperature of the air inside the tube shows a drop of 5° F. inside the tube at moderate speaker power levels when the ambient surrounding temperature is about 70° F. Such a reduction in voice coil temperature is significant. When an amplifier (e.g., 320) is mounted in the tube as well the air temperature reduction due to the use of a high thermally conductive material such as aluminum will be even more significant.

Low Profile, Shallow Speaker Embodiments

The various embodiments of the present invention permit the designer to maximize air movement in a given mounting depth with a configuration that optimizes the operation of the moving parts (i.e., diaphragm, suspension and voice coil) in the electromagnetic environment that complements the fixed mechanical structural configuration of the non-moving parts. In one embodiment, this invention allows the designer to have an over excursion (outward/inward limiter) that is optimized with the available mounting depth. For example, the present invention allows the designer to have a 15" diameter speaker that fits in a mounting depth of as little as 3.5" with a diaphragm excursion of approximately ± 1 ", while a conventional speaker with the same size working piston requires a mounting depth of 6" to 7".

FIGS. 36A through 45B illustrate a variety of embodiments of low profile, shallow speaker embodiments of the present invention that are mountable in shallow, small clearance locations. To simplify the understanding of each of these embodiments, elements in the various figures that are the same have been given the same reference number. Those elements that are modified and which perform the same or similar function have the same number with the first use without a prime and for each variation one or more primes have been added to the reference number.

FIG. 36 show a first embodiment low profile, overhung, shallow speaker design with FIG. 36A in the unexcited position, FIG. 36B in the maximum outward excursion position, and FIG. 36C in the maximum inward excursion position. Included is a low profile frame or basket 402 that mounts to baffle board 400 in the installed location. Basket 402 has a bottom thickness of "H". In the bottom center of basket 402 is a typical overhung magnet/voice coil audio motor with an upwardly extending steel doughnut with an outwardly extending flange 410 with that flange having a thickness of "T". Mounted on the flange of doughnut 410 is a circular magnet 406 having a center hole that has a larger diameter than the diameter of the upwardly extending portion of the doughnut. Magnet 406 has a thickness of 2α . On top of magnet 406 is a steel ring 408 having outer and inner diameters that are approximately the same as those diameters of magnet 406. Ring 408 also has a thickness "T".

Additionally, there is a stiff, substantially fiat diaphragm 404 with the diameter of the flat area being larger than the outer diameter of magnet 406. The outer most edge of diaphragm 404 is shown having a "V" shaped outer edge that extends downward and away at approximately 60°, however that specific angle is not critical to the design. Diaphragm 404 is ideally made of a material such as

honeycomb, thin aluminum, or other composite and non-composite light-weight materials; conventional cone materials will not work in this application since the diaphragm is substantially fiat and light-weight. Diaphragm 404 is suspended with two matched surrounds: an upwardly extending flexible surround 418 having an inner edge attached to the top of the outwardly extending leg of the "V" shaped edge of the diaphragm and an outer edge attached to the top, outer most flange of basket 402; and a downwardly extending flexible surround 420 having an inner edge attached to the bottom of the inner leg of the "V" shaped edge of the diaphragm and an outer edge attached to a point within basket 402 below the top, outer most flange. With surrounds 418 and 420 mounted in this way, maximum linearity of the inward/outward strokes of the speaker is achieved. Between the attachment points of surrounds 418 and 420, ventilation holes 426 have been formed around the circumference of basket 420. Attached to the lower center of diaphragm 404 is voice coil 412 that fits loosely around the upwardly extending portion of steel doughnut 410 with the upper most turn of the coil of voice coil 412 being spaced 0.5α below the inner surface of the diaphragm and the coil winding having a height of 2α in this overhung configuration. By making the height of the coil winding the same as the thickness of the magnet makes it possible to minimize the overall height of the speaker in every excited and unexcited positions of the diaphragm. With respect to each of the views of FIGS. 36A, 36B and 36C, and each of the embodiments discussed below, the thickness of the diaphragm adds the same amount to the overall height of the speaker in each illustrated state, and since the thickness of the diaphragm can vary depending on the material used, for comparison purposes, the thickness of the diaphragm is not included in the height calculations.

FIG. 36A illustrates the position of the various components of this speaker embodiment when no current is flowing through voice coil 412 and when the speaker is not being driven. In this position, surrounds 418, 420 are relaxed with the lower half of the coil winding opposite the upper half of the magnet and the inner surface of diaphragm 404 spaced apart from the upper surface of ring 408 by a distance of α . Thus the overall height of the speaker is the spacing between diaphragm 404 and ring 408, α , plus the thickness of ring 408, T, plus the height of magnet 406, 2α , plus the thickness of the flange of 410, T, plus the thickness of the bottom of basket 402, H, for a total of $3\alpha+2T+H$.

In FIG. 36B the speaker is in the maximum outwardly extending position with the surrounds both stretched upward and the bottom coil of the voice coil even with the upper surface of ring 408. In this position the speaker achieves the maximum height possible. Here the spacing between ring 408 and diaphragm 404 is 2.5α (the height of the coil, 2α , plus the spacing of the upper most turn of the coil 0.5α from the bottom surface of the diaphragm). Thus the overall height of the speaker in this state is that 2.5α , plus the thickness of ring 408 and the flange 410, each T for a total of $2T$, plus the height of the magnet 2α , plus the thickness of the bottom of the basket, H, for a total of $4.5\alpha+2T+H$.

In FIG. 36C the speaker is in the maximum inwardly extending position with the surrounds both stretched inward and the overall height of the coil of voice coil 412 directly adjacent magnet 406 with the inward pull of the speaker being limited by the inner surface of diaphragm 404 coming into contact with the top surface of ring 408. Note that a circular groove 414 has been provided in the flange to protect the bottom edge of the voice coil from bottoming out with the flange. In this position the speaker achieves the

minimum height possible. That height is the thickness of the magnet, 2α , plus the thickness of ring 408 and the flange, each T, and the thickness of the bottom of the basket, H, for a total of $2\alpha+2T+H$.

Note that the outermost edge of suspension system 418, 420 and diaphragm 404 is entirely outside the outer diameter of magnet 406, thus allowing the suspension to extend below the top surface of ring 408 with surround 420 nearly extending to the bottom of the basket on the maximum inward excursion of the voice coil and diaphragm as shown in FIG. 36C. Thus, the suspension operational depth is not a limiting factor of the speaker basket design and the actual mounting depth of the speaker. As noted above the mounting depth and cone wobble control are interrelated in the speakers of the present invention; the closer the outer portion of the suspension is to an inner one, the chance of wobble increases as the mounting depth of the speaker becomes shallower. As can be seen in FIGS. 36A, B and C the spacing between the two surrounds 418 and 420 is maintained throughout the full range of travel of the diaphragm, thus minimizing the possibility of wobble.

FIG. 39 shows a second embodiment of an overhung, low profile speaker that is similar to that of FIG. 36A, the difference being that surrounds 418 and 420 have been replaced with a single bladder 422. In construction, bladder 422 is similar to a bicycle tube with the outer most side connected to inside top edge of basket 402 and an opposite side connected to the bottom of the outer most leg of the "V" shaped edge of diaphragm 404. Mounted in that way, a portion of bladder 422 extends upward like surround 418 while another portion extends downward into basket 420 like surround 420. In operation, bladder 422 performs similarly to the combination of surrounds 418 and 420 as discussed above in relation to FIGS. 36A, 36B and 36C.

By connecting the outer most side of bladder 422 to a lower point within basket 402 that is approximately horizontally even with the underside of the outer most leg of the "V" shaped edge of the diaphragm rocking of the diaphragm during speaker operation is minimized. Bladder 422 could be manufactured by injection molding and the wall thickness could be increased as necessary to achieve the desired performance. Additionally, to reduce internal pressure that develops during extreme in/out strokes, bladder 422 can have ventilation holes around the circumference to reduce internal pressure to allow air trapped within to leak into the space in which the speaker is mounted through ventilation holes 426. The overall height calculations for this embodiment are the same as for the first embodiment of FIG. 36A.

The third overhung, low profile speaker embodiment of FIG. 40 is also similar to the embodiment of FIG. 36A with two modifications—the outer edge shape of the diaphragm and the inner and outer surrounds. The outer edge of diaphragm 404" of this embodiment has two suspension points, one being an upper outwardly small "V" shaped finger 405 that is slightly below the top surface of diaphragm 404", and a downward extending finger 407 outside the diameter of magnet 406. Downward extending finger 407 also has formed to the end thereof a small outwardly extending flange. An outwardly extending surround 418' is connected between the outer most leg of the small "V" shaped finger 405 and the top flange of basket 402, similar to surround 418 in FIG. 36A. Additionally, a spider 422 is connected between the small outwardly extending flange of downwardly extending finger 407 and a point within basket 402 below the top flange and ventilation holes 426, similar to the connection point of surround 420 in FIG. 36A. It should be noted that in this configuration spider 422 is

mounted entirely outside the outer diameter of magnet 406, unlike the design of conventional speakers where the spider/cone connection is mounted directly over the magnet by a distance that is related to the desired travel of the speaker cone. With spider 422 mounted to the side of magnet 406 as in FIG. 40, the additional speaker height required in a conventional speaker is eliminated thus reducing the overall height of the speaker making a low profile speaker possible. In operation, surround 418' and spider 422 perform similarly to the combination of surrounds 418 and 420 as discussed above in relation to FIGS. 36A, 36B and 36C. The overall height calculations for this embodiment are the same as for the first embodiment of FIG. 36A.

FIG. 37 show a fourth embodiment of an overhung, low profile speaker of the present invention. This embodiment, as will be seen, has built in stops that define the maximum Inward and outward travel of the diaphragm. Included in this embodiment is a speaker basket 402' with an outwardly extending upper flange that mounts to baffle board 400 of the mounting location of the speaker. Basket 402' has a bottom thickness "H". Mounted centrally within basket 402' is a post 428 having a threaded upper end 430 with the overall height of post 428 being less than the height of basket 402' from the bottom to the mounting flange. Also included is steel ring 408 magnetically adhering to the bottom of circular magnet 406 which in turn magnetically adheres to the flange of circular steel doughnut 410' with a hole therethrough that is tapped at the upper end. The flange of doughnut 410' and ring 408 each have a thickness "T", and magnet 406 has a thickness $2\alpha'$ (note the distance α' in this figure is not necessarily the same as the distance α in FIG. 36). Doughnut 410' is screwed onto the top of post 428 with the ring/magnet/doughnut 408, 406, 410' assembly having a substantially uniform diameter that is suspended above the bottom of the basket. Note that doughnut and flange 410' is substantially the same as doughnut 410 in FIG. 36 with the addition of the tapped center hole and being mounted inverted to that of FIG. 36.

In this embodiment, diaphragm 404' consists of two elements—a flat ridged top disk 413 and a circular enclosure 409 to the top of which top disk 413 is coupled. Circular enclosure 409 has cylindrical open interior with an inner diameter that is greater than the diameter of assembly 410, 406, 408' that opens to the opening in the basket. Through the center of bottom portion 411 of enclosure 409 is a circular hole that has a diameter substantially equal to that of voice coil 412 with the lower end thereof coupled within the bottom hole of enclosure 409. Voice coil 412 extends upward and fits loosely around the downwardly extending portion of steel doughnut 410' with the lower most turn of the coil of voice coil 412 being spaced $0.5\alpha'$ above the inner surface of bottom portion 411 and the coil winding has a height of $2\alpha'$ in this overhung configuration. Additionally, the inner depth of enclosure 409 is $2\alpha'$ Extending radially outward from enclosure 409 is a ring with the outer edge undercut inward shown here at approximately 45° , however the undercut angle is not critical to the operation of the speaker. The outwardly extending ring of the enclosure is coupled to the mouth of the basket by surrounds 418, 420 similar to that shown in FIG. 36A.

FIG. 37A illustrates the position of the various components of this speaker embodiment when no current is flowing through voice coil 412 and when the speaker is not being driven. In this position, surrounds 418, 420 are relaxed with the upper half of the voice coil winding opposite the lower half of the magnet, and the inner surface of plate 413 of diaphragm 404' is spaced apart from the upper surface of the

21

flange of **410'** by a distance α' . Thus the overall height of the speaker is the distance between diaphragm **404'** and the upper surface of **410'**, α' , plus the thickness of **410'**, T, plus the height of magnet **406**, $2\alpha'$, plus the thickness of ring **408**, T, plus the spacing between ring **408** and the inner surface of **411**, α' , plus the thickness of **411**, J, plus the distance between **411** and the bottom of the basket, α' , plus the thickness of the bottom of basket **402'**, H, for a total of $5\alpha'+2T+H$.

In FIG. **37B** the speaker is in the maximum outwardly extending position with the surrounds both stretched upward, voice coil **412** is fully within the inner diameter of magnet **406**, and the bottom **411** of enclosure **409** is in contact with the lower surface of ring **408** being pulled into that position by the fact that voice coil **412** is connected to **411**. Note that a circular groove **416** has been provided in the flange to protect the top edge of the voice coil bobbin from bottoming out with the flange. This contact between **411** and the bottom of **408** stops the upward travel of diaphragm **404'**. In this position the speaker achieves the maximum height possible. In this configuration the height of the speaker is the spacing between plate **413** of diaphragm **404'** and **410'**, $2\alpha'$, plus the thicknesses of **410'** and ring **408**, each T, plus the height of magnet **406**, $2\alpha'$, plus the thickness of **411**, J, plus the distance between **411** and the bottom of the basket, plus the thickness of the bottom of basket **402'**, H, for a total of $6\alpha'+2T+J+H$.

In FIG. **37C** the speaker is in the maximum inwardly extending position with the surrounds both stretched inward and the overall height of the coil of voice coil **412** totally withdrawn from within the inner diameter of magnet **406** with the inward pull of the speaker being limited by the bottom surface of **411** coming into contact with the bottom of basket **402'**. In this position the speaker achieves the minimum height possible. That height is the thicknesses of **410'** and **408**, each T, plus the height of the magnet, $2\alpha'$, plus the thickness of **411**, J, plus the thickness of the bottom of basket **402'**, H, for a total of $4\alpha'+2T+J+H$.

FIG. **38** show a fifth embodiment of an overhung, low profile speaker of the present invention that is similar to the fourth embodiment of FIG. **37** with the only difference being the configuration of the diaphragm which gives the speaker the same height regardless of the position of the diaphragm for all levels of excitation. This embodiment, as will be seen, also has built in stops that define the maximum inward and outward travel of the diaphragm. Given that only the diaphragm is different from the embodiment of FIG. **37**, only the configuration of the diaphragm will be discussed here. Diaphragm **404''** is similar to diaphragm **404'** of FIG. **37**, the difference being that diaphragm **404''** does not have top plate **413** and the depth of enclosure **411'** is only $2\alpha'$ as compared to the $4\alpha'$ depth of enclosure **411** of diaphragm **404'** of FIGS. **37**. Thus, each of FIG. **38A**, B and C are similar to FIGS. **37A**, B and C with all of the components in the same positions without plate **404'** above **410'**.

Thus the unexcited height of the speaker in FIG. **38A** is the thicknesses of each of **410'** and **408**, each being T, plus the height magnet **406**, $2\alpha'$, plus the spacing between ring **408** and the inner surface of **411'**, α' , plus the thickness of **411'**, J, plus the distance between **411'** and the bottom of the basket, α' , plus the thickness of the bottom of basket **402'**, H, for a total of $4\alpha'+2T+J+H$.

The maximum outward excited height of the speaker in FIG. **38B** is the thicknesses of each of **410'** and **408**, each being T, plus the height magnet **406**, $2\alpha'$, plus the thickness of **411'**, J, plus the distance between **411'** and the bottom of

22

the basket, $2\alpha'$, plus the thickness of the bottom of basket **402'**, H, for a total of $4\alpha'+2T+J+H$.

Similarly, the maximum inwardly excited height of the speaker in FIG. **38C** is the thicknesses of each of **410'** and **408**, each being T, plus the height magnet **406**, $2\alpha'$, plus the spacing between ring **408** and the inner surface of **411'** which is the same as the winding height of voice coil **412**, $2\alpha'$, plus the thickness of **411'**, J, plus the thickness of the bottom of basket **402'**, H, for a total of $4\alpha'+2T+J+H$.

FIG. **41** show a sixth embodiment of an overhung, low profile speaker of the present invention that is similar to the first embodiment shown in FIG. **36**. The only differences between these two embodiments is in the outer edge of the diaphragm and the suspension between the diaphragm and the speaker basket. The various heights of this embodiment are the same as those of the first embodiment.

Diaphragm **404'''** of this embodiment has an outer edge that is a two tine, horizontally extending fork with the upper surface of diaphragm **404'''** forming a first tine **426** of the fork with the second tine **428** spaced apart from and below the first tine. In place of surrounds **418** and **420**, the present embodiment utilizes a single support bladder **424** with a first mounting tab **430** extending outward for attachment to the outwardly extending flange of basket **402**, and a second mounting tab **432** extending outward on the opposite side of the bladder from tab **430**. Tab **432** is sized to fit between, and be captured within, the space between tines **426** and **428** on the outer edge of diaphragm **404'''**. In the unexcited state of the speaker shown in FIG. **41A**, substantially equally sized portion of bladder **424** extend upward from basket **402** and downward into basket **402**, similar to surrounds **418** and **420** in FIG. **36A**. It can be seen from the maximum outwardly excited state shown in FIG. **41B** and the maximum inwardly excited state shown in FIG. **41C**, that bladder **424** is stretched in the same way as do surrounds **418** and **420** in FIGS. **36B** and **36C**. Thus the performance of this embodiment is substantially the same as the first embodiment of FIG. **36**.

FIG. **42** illustrate a first underhung, low profile speaker embodiment of the present invention. This embodiment is similar to the overhung embodiment of FIGS. **36** with only three changes. One change is the replacement of magnet **406** that has a height of $2\alpha'$ (FIG. **36**) with magnet **406'** with a height of "M" (FIG. **42**) in the same location of the structure. A second change is the replacement of steel ring **408** that has a thickness of "T" (FIG. **36**) with a steel ring **408'** with a thickness of $2\alpha'$ (FIG. **42**). The third change is the replacement of voice coil **412** with a coil winding that is $2\alpha'$ high and spaced $0.5\alpha'$ below the underside of diaphragm **404** (FIG. **36**) with a voice coil **412'** with a coil winding that is $0.5\alpha'$ high and spaced $2\alpha'$ below the underside of diaphragm **404** (FIG. **42**). With these changes the underhung, low profile speaker of FIGS. **42A**, B and C performs in the same way as the overhung, low profile speaker of FIGS. **36A**, B and C with the same overall heights of the speaker in each of the illustrated excitation/non-excited positions illustrated in FIGS. **36A**, B and C and FIGS. **42A**, B and C, respectively.

Namely, In FIG. **42A** the overall height is the spacing height between the under side of diaphragm **404** and the top side of ring **408'**, α' , plus the thickness of ring **408'**, $2\alpha'$, plus the height of magnet **406'**, "M" (that is equal to "T"), plus the thickness of the flange on **414**, "T", plus the thickness of the bottom of basket **402**, "H", for an overall height of $3\alpha'+T+M+H$ which is equal to $3\alpha'+2T+H$ in FIG. **36A**.

In FIG. **42B** the overall height is the spacing of the winding of voice coil **412'** from the underside of the dia-

phragm, 2α , plus the height of the coil winding, 0.5α plus the thickness of ring 408', 2α , plus the height of magnet 406', "M" (that is equal to "T"), plus the thickness of the flange on 414, "T", plus the thickness of the bottom of basket 402, "H", for an overall height of $4.5\alpha+T+M+H$ which is equal to $4.5\alpha+2T+H$ in FIG. 36B.

In FIG. 42C the overall height is the spacing of the winding of voice coil 412' from the underside of the diaphragm or the thickness of ring 408', 2α , plus the height of magnet 406', "M" (that is equal to "T"), plus the thickness of the flange on 414, "T", plus the thickness of the bottom of basket 402, "H", for an overall height of $2\alpha+T+M+H$ which is = to $2\alpha+2T+H$ in FIG. 36C.

A second embodiment of an underhung, low profile speaker of the present invention is illustrated in FIG. 43. This embodiment is also similar to the first overhung embodiment of FIG. 36 with two changes to the speaker structure. One change is the replacement of voice coil 412 with a coil winding that is 2α high and spaced 0.5α below the underside of diaphragm 404 (FIG. 36) with a voice coil 412' with a coil winding that is 0.5α high and spaced 2α below the underside of diaphragm 404 (FIG. 43). The other change is the replacement of steel ring 408 (FIG. 36) with a second steel doughnut 408" with a flange inverted over magnet 406. The doughnut portion of 408" having an outer diameter that is substantially the same as the inner diameter of magnet 406, and an outer diameter that is substantially less than the outer diameter of the doughnut portion of 410 thus leaving a space between the two doughnuts that is significantly wider than the thickness of the mounting ring of voice coil 412'. The doughnut portion of 408" extends down the inside surface of the magnet, neatly the entire height of the magnet leaving a space between the bottom end of 408" and the upper surface of the flange of 410. The flange portion of 408" having a thickness, "T", that is the same as the thickness of ring 408 in FIG. 36. The doughnut portion of 408" being needed to extend the effect of the upper pole of magnet 406 (typically considered to be the North pole) into the space traversed by the winding of voice coil 412' to permit operation of the speaker in an underhung configuration.

FIG. 45 show an embodiment of a speaker with a replaceable voice coil, the speaker otherwise being similar to the speaker shown in FIG. 40. In FIG. 45A there is shown in the upper part of that figure, the removable/replaceable voice coil assembly and in the lower part of that figure the assembled other components of the speaker. In addition to what is shown in FIG. 40, the lower part of FIG. 45A also includes a modified diaphragm 434 that is similar to diaphragm 404" with the center removed from above the location for the voice coil. The diameter of the center hole in diaphragm 434 being slightly larger than the diameter of voice coil 412" shown in the upper part of FIG. 45A. Forming the edge of the center hole in diaphragm 434 is a bifurcated conductive internally threaded ring 446 that is electrically connected to conductor 436 that is molded into the diaphragm and passes through the space between surround 418' and spider 422 on the left side and is then coupled to connector 440 that is disposed to be connected to an amplifier to apply signal to the voice coil. Similarly, the right side of ring 446 is electrically connected to conductor 438 that is molded into the diaphragm and passes through the space between surround 418' and spider 422 on the right side and is then coupled to connector 442 that is also disposed to be connected to an amplifier to apply signal to the voice coil.

The voice coil assembly in the upper portion of FIG. 45A includes voice coil 412" with the coil winding on a typical voice coil bobbin. One lead wire 436 of the coil is shown extending to the top of the bobbin on the left side, while the other lead wire of the coil is shown extending to the top of the bobbin on the right side. Surrounding the top of the voice coil bobbin is a bifurcated conductive externally threaded ring 444 that is described more fully below. The left conductive half of ring 444 has lead wire 436 connected thereto, while the right conductive half of ring 444 has lead wire 438 connected thereto. Then covering the top of the bobbin is circular cap 434' that closes the center of diaphragm 434 when voice coil 412" is installed as in FIG. 45B. Voice coil 412" is installed by inserting the lower end of the bobbin first through the central hole in diaphragm 434 and then screwing ring 444 into ring 446 and positioning the left half of ring 444 on the bobbin opposite the left half of ring 446 which then causes the right half of ring 444 to be in contact with the right half of ring 446. When so positioned, lead wire 436 is electrically connected, through the left half of rings 444 and 446 with wire 436 and connector 440, and similarly lead wire 438 is electrically connected, through the right half of rings 444 and 446 with wire 438 and connector 442.

The details of rings 444 and 446 are shown in FIGS. 44A and 44B. In FIG. 44A ring 444 can be seen to consist of right and left halves which are bound together with non-conductive elements 445 (e.g., plastic or epoxy) to form the ring. Also shown in FIG. 44A are ring 446 sections 446L and 446R in an exploded relationship with respect to ring 444. Then in FIG. 44B, the two halves of ring 446 are shown assembled as is ring 444, with non-conductive elements 448 joining the two halves while electrically isolating one half from the other.

FIG. 46 are provided to illustrate a second embodiment of a speaker with a removable/replaceable cone or voice coil, or both. While the views shown in FIG. 46 are that of a conventional speaker, the same techniques can be used with low profile speaker. FIG. 46A shows an exploded view of the speaker of the this embodiment, and FIG. 46B shows the same speaker fully assembled. The speaker is to be mounted on a baffle board 500 with a flange of basket 502. Shown at the bottom of the basket is magnet assembly 504. Within the basket and above magnet 504, is a spider assembly 506 with a center cylinder 512 having external screw threads 514 around the upper end thereof. Cylinder 512 and threads 514 can be made of a non-conductive material, or threads 514 could be a conductive ring 446 such as that of FIG. 44B. On the left side of cylinder 512, a conductive wire (not shown) extends from threads 514, through spider 506 to an external connector 510 that is disposed to be connected to an audio source. Similarly, on the right side of cylinder 512, a conductive wire (not shown) extends from threads 514, through spider 506 to an external connector 508 that is disposed to be connected to the same audio source. The purpose of these wires and external connectors will soon become apparent. Extending above the flange is a rim with a concave half circle groove 532.

Also included is a cone 526 with surround 528 bonded to the outer edge of the cone. Beneath the center of cone 526 is a voice coil 520 on a bobbin with one lead 522 from the coil extending up the left side of the bobbin to the underside of the cone, and on the right side of the bobbin the other lead 524 of the coil also extends upward to the under side of the cone. The bobbin can either be permanently fixed to the under side of the cone, or it can with ring 444 (FIG. 44A) to the top edge of the bobbin screwed into a ring 446 that is bonded to the underside of the cone.

Also connected to the underside of the cone, outside of, and spaced apart from, of the bobbin, is a downwardly extending cylinder that is approximately one third the length of the bobbin with an internal thread at the lower end thereof. That cylinder includes a left conductive portion **516** and a right conductive portion **518** that are connected at their cone end to lead wires **522** and **524**, respectively. Conductive portions **516** and **518** could be left and right sides of a ring such as ring **446**, or lead wires **522** and **524** could be extended from the cone down into the internal threads of **516** and **518**.

The final step of assembly of such a speaker is the lowering of the cone/voice coil assembly to the mouth of basket **502** with the winding of the voice coil passing through the central cylinder supported by the spider with the windings of the coil extending to the magnet assembly. The cone/voice coil assembly is attached to the cylinder/spider assembly by mating the internal threads of the cylinder attached to the cone with the outer threads of the cylinder taking care to position the cone/voice coil assembly such that lead wires **522** and **524** are coupled to external connectors **510** and **508**, respectively. Once the voice coil is positioned as such, the final step of assembly is the placement of the outer edge of surround **528** to the outside of the rim on the basket flange opposite the concave half circle groove **532**. Then elastic ring **530** is placed around the so located outer edge of the surround to seat the edge of the surround in groove **532** and retained in that position by elastic ring.

With a speaker of this design, a user of such a speaker will be able to replace either the voice coil of the cone should they, or the surround be however damaged. Also the user will be able to interchange the cone and/or voice coil with those of a different design or configuration to produce a different audio response and sound from the speaker.

Anti-Wobble Voice Coil Speaker

Referring next to FIG. **47** there is shown, in cross-section, or a center slice of, a convention speaker with the spider connected to the top edge of the voice coil bobbin and without cross-hatching to minimize confusion. This speaker includes a basket **600** with the excitation motor mounted in the bottom of basket **600**. The motor includes a steel center pole piece **610** centered in the bottom of basket **600** and extending upward away from the bottom of the basket into the interior thereof. Next there is shown a pair of circular magnets **608** resting on an outward extending flange of pole piece **610** and surrounding the upward extending portion of pole piece **610**. Then, on the top surface of the top magnet **608** is a circular steel top plate **606** having a circular center hole that has a diameter that is somewhat larger than the outer diameter of pole piece **610** to allow room for the lower portion of voice coil bobbin **602** and the voice coil **604** wound thereon to pass within a narrow space between the outer surface of pole piece **610** and the inner hole through top plate **606**. Thus the inner diameter of bobbin **604** is slightly larger than the outer diameter of pole piece **610** and the outer diameter of the combination of bobbin **602** and voice coil **604** wound thereon is smaller than the diameter of the center hole in top plate **606**.

Attached to the top rim **613** of basket **600** is the outer edge of surround **614** with the inner edge of surround **614** attached to the outer edge of cone **616**. Additionally, cone **616** has a center hole therethrough that is substantially the same diameter as the diameter of bobbin **602**. Basket **600** includes an interior flange **615** that extends completely around the inner surface of basket **600** at a point that is

slightly deeper in basket **600** than the top edge of bobbin **602** when the fully assembled speaker is not excited. Additionally, included is a spider **612** having an outer edge with a diameter that is substantially the same as the inner diameter of basket **600** at flange **615** and a center hole that has substantially the same diameter as bobbin **602**. The outer edge of spider **612** is attached to flange **615**. The edges defining the center holes of cone **616** and spider **612** are both attached around bobbin **602** near the top edge thereof at connection point **618**. To complete the conventional speaker of FIG. **47**, a non-structural dust cap **620**, having an outer diameter that is greater than the diameter of bobbin **602**, has that outer diameter edge attached to the outer face of cone **616** to cover the center hole in bobbin **602**.

FIG. **48A** shows, in cross-section, or a center-slice of, another embodiment of a speaker of the present invention that minimizes wobble of the voice coil bobbin during excursions during use that is also easily assembled. To permit operational comparisons below of the speaker of this embodiment with the conventional speaker of FIG. **47**, the basic structure of the embodiment shown in FIG. **48A** includes many of the same components as in the conventional speaker of FIG. **47**. Where the components are the same, the same reference numbers are used in FIG. **48A** as in FIG. **47**. Those components include: basket **600**, voice coil bobbin **602**, voice coil **604**, magnet top plate **606**, circular magnets **608**, magnet center pole piece **610**, spider **612**, basket top rim **613**, surround **614**, basket interior flange **615** and cone **616** with dust cap **620** not being needed.

The embodiment of FIG. **48A** additionally includes three components that are not in a conventional speaker. The components are joining collar **626**, extension ring **628** and lateral support diaphragm **622**. The interaction of these components can be more clearly be seen in the partial exploded view of FIG. **48B**. Joining collar **626** is circular in shape with an inner diameter that is substantially the same as the outer diameter of bobbin **602**, has a straight top edge and an outward flaring lower edge. Joining collar **626**, when placed around the top edge of bobbin **602** is glued in place with the top edges of joining collar **626** and bobbin **602** substantially even with each other and the outward flaring lower edge of joining collar **626** being on the order of $\frac{1}{4}$ " to $\frac{1}{2}$ " below the top edge of bobbin **602** and flaring outward on the order of $\frac{1}{8}$ " to $\frac{1}{4}$ ". These dimensions with vary depending on the size of the speaker and the thickness of the material from which spider **612** and cone **616** are constructed which will be better understood below.

Once joining collar **626** is in place on bobbin **602**, the inner edge of spider **612** is placed around the upper edge of bobbin **602** in contact with the outward flaring lower edge of joining collar **626**, either before or after the voice coil **604** end of bobbin **602** is placed in the space between center pole piece **610** and top plate **606** with the outer edge of spider **612** resting on flange **615** to which it is attached. Next, cone **616**, with surround **614** attached around the outer edge is installed by placing the inner edge that defines the center hole of cone **616** around the top end of bobbin **602** and joining collar **626** with that inner edge of cone **616** on top of the inner edge of spider **612**, against the flaring lower edge of joining collar **626** where they are fastened with glue or another appropriate fastening means. In this position, the outer edge of surround **614** is resting on top rim **613** of basket **600** to which it is attached. At this point in the assembly, bobbin **602** and voice coil **604** are positioned substantially in the at rest position of the speaker when no current is flowing in voice coil **604**, being supported in that position by spider **612** and surround **614**.

Then the lower end **630** of extension ring **628** is placed on the combined upper ends of bobbin **602** and joining collar **626**. From FIG. **48B** it can be seen that the lower end **630** of extension ring **628** is bifurcated with the width of the notch therein substantially the same as the combined thickness of bobbin **602** and joining collar **626** with the diameters of the two sides of the notch being substantially the same as the inner diameter of bobbin **602** and the outer diameter of joining collar **626**, respectively, with lower end **630** glued in place. The height of extension ring **628**, as will be seen from the discussion below, is selected so that when lateral support diaphragm **622** is in place the outer edge thereof extends outward and makes contact with cone **616** at substantially the point at which cone **616** is joined to surround **614** with lateral support diaphragm glued to cone **616** and surround **614** at that point. Extension ring **628** could be made of any material with a non-conductive material such as plastic being preferred, and can be formed with air vents **634** through the side walls and spaced substantially uniformly around ring **628**. The upper end **632** of extension ring **628** as viewed in cross-section as in FIG. **48B** is in the form of a three tined fork with the center tine slightly shorter than the two outer tines.

To complete the assembly of the speaker, lateral support diaphragm **622** is then put in place. As can be seen in FIGS. **48A** and **48B**, on the under side of diaphragm **622** two centering features are formed thereon. One is a centering ring **624** that is perpendicular to the under side of lateral support diaphragm **622** with the center of the circle formed by centering ring **624** being the center of lateral support diaphragm **622**, and the inside diameter of centering ring **624** is substantially the same as the outer diameter of extension ring **628**. Slightly spaced apart from, and inside centering ring **624** is a circular positioning bead **636**. Circular positioning bead **636** could be formed as a continuous ring of material or spaced apart raised dots in a circle inside centering ring **624**.

When lateral support diaphragm **622** is attached to upper end **632** of extension ring **628**, the outer surface of extension ring **628** abuts the inner side of centering ring **624** with the outer tines of upper end **632** on opposite sides of circular positioning bead **636**, and the free end of the center shorter tine of upper end **632** in direct contact with the top of positioning bead **636**. Positioning bead **636** and the upper forked end **632** of extension ring **628** have been included to provide more positive connection between the under side of lateral support diaphragm **622** and extension ring **628**, however satisfactory operation of the speaker would be provided without those features. To complete the assembly of the speaker, the outer edge of lateral support diaphragm **622** is attached to the outer face of cone **616** and surround **614**, at the point of connection between cone **616** and surround **614**, with a suitable glue. Lateral support diaphragm **622** can be made of any suitable material that provides the desired stiffness, e.g., metal, pressed paper, carbon fiber plastics, any of these materials with a foam or honeycomb interior, other composite and non-composite light-weight materials or any other material with the desired structural characteristics; conventional cone materials will not work in this application.

Lateral support diaphragm **622** functions similarly to the "cone" of a conventional speaker; diaphragm **622** is the sound radiator in the speaker of the present invention wherein the cone is the sound radiator of the conventional speaker. In the present invention the lateral support diaphragm **622** is stiff, substantially flat and light-weight. Additionally, cone **616** can be made of conventional mate-

rials since the only purpose of cone **616** is one of the structural elements that minimize or eliminate wobble of bobbin **602**.

The ends of the wire of voice coil **604** are typically glued to, and dressed up the outside of bobbin **602** toward the upper end portion thereof. Those wires could be then dressed up the underside of cone **616** for attachment to other wires that are attached to input terminals (not shown). Alternatively, the ends of the voice coil wires that have been dressed up the outside of bobbin **602** could be connected to wires that have been placed through spider **612** with the other end of those wires close to basket **600** then attached to input terminals (not shown) mounted on the basket.

In operation, when the speaker is placed in an enclosure, air is free to flow through the mesh or open construction of spider **612**, through vent holes **634** in extension ring **628** and through vent holes **638** through cone **616** that are evenly spaced therearound. Cone **616** serves as one of the structural components of the voice coil bobbin **602** anti-wobble triangle shown in FIG. **48A** (actually a triangular ring in the complete speaker). That triangle includes cone **616** as one side, the portion of lateral support diaphragm **622** outside of centering ring **624** as a second side, and the third side is the combination of extension ring **628** and the end of bobbin and joining collar **626** above the attachment flange. That triangle, as a result of the stiffness of the components that form that triangle, is rigid and holds its shaped during operation of the speaker. The anti-wobble triangle assembly together with spider **612** attached to the lower corner of the triangle substantially eliminates wobble of bobbin **602** at all positions relative to the magnet assembly during excitation of the speaker.

Further, cone **616** could have air vent holes **638** formed therethrough and evenly placed therearound to vent the anti-wobble support triangle. Since the upper face of cone **616** is totally enclosed beneath lateral support diaphragm **622**, cone **616** is non-functional with respect to radiating sound from the speaker; diaphragm **622** is the sound radiator. Thus vent holes **638** through cone **616** are not detrimental to sound reproduction. Vent holes **638** in cone **616** and vent holes **634** in extension ring **628** keep the pressure within the triangle the same as the rest of the space within the speaker beneath surround **614** and lateral support diaphragm **622** to minimize the possibility of varying the shape of the anti-wobble triangle by pressure that could be greater inside or outside the triangle.

It should also be kept in mind that when the speaker is viewed from above, the shape of the mouth of basket **600** and lateral support diaphragm **622** is not limited to being round. That shape can be any that is desired for whatever reason. While round and oval are probably the most common shapes since they are the most practical, the present invention can be used with speakers that have a triangular, square, rectangular or any polygonal shape.

The next several figures are presented to illustrate the various bending forces on the various components of the conventional speaker of FIG. **47** that cause wobble of the voice coil bobbin in comparison with cancellation of forces in the sub-zero speaker of the present invention of FIG. **48A**.

FIG. **49A** illustrates the conventional speaker of FIG. **47** with the voice coil bobbin **602** drawn inward by signal force **640** to the position of the maximum inward stroke. As bobbin **602** moves from the unexcited position (at rest), spider **612** applies a tension on the top edge of bobbin **602**. In the drawn inward position illustrated here, spider force **648** has a horizontal component that is away from the center of the speaker, as well as an upward vertical component. The

resiliency of surround **614** also creates an outward and upward force on the outer edge of cone **616**. These forces create bending forces and moments on both bobbin **602** and cone **616**.

These forces subject the top portion, or neck, of bobbin **602** to bending forces and moments **650** that tend to collapse the neck of bobbin **602** inward whenever signal force **640** is drawing bobbin **602** inward. These forces and moments increase in proportion to the strength of an inward drawing signal force **640** and are greatest when bobbin **602** is drawn inward to the maximum position as shown in FIG. **49A**. Similarly, cone **616** experiences bending forces: outward **646** on the outer portion of cone **616**, and inward **644** on the inner portion of cone **616**. Rigid dust cap **620** contributes to the cone bending force direction on the inner and outer portions of cone **616**. Due to variations in the stiffness of cone **616** at various locations and variations in the thickness and possible internal defects in bobbin **602**, the effect of the various forces produce differences in the amount of bending of cone **616** and the upper region of bobbin **602** relative to different signal forces **650** that cause variations in the spacing of the lower portion of bobbin **602** between magnet **608** and center pole piece **610**. This results in wobble of bobbin **602** on the in-stroke.

FIG. **49B** illustrates the conventional speaker of FIG. **47** with the voice coil bobbin **602** driven outward by signal force **640** to the position of an extreme outward stroke. As bobbin **602** moves from the unexcited, the at rest, position spider **612** applies a tension on the top edge of bobbin **602**. In the driven outward position illustrated here, spider force **648** has a horizontal component that is away from the center of the speaker, as well as a downward vertical component. The resiliency of surround **614** also creates an outward and downward force on the outer edge of cone **616**. These forces create bending forces and moments on both bobbin **602** and cone **616**.

These forces subject the top portion, or neck, of bobbin **602** to bending forces and moments **650** that tend to expand, flare outward, the neck of bobbin **602** whenever signal force **640** is driving bobbin **602** outward. These forces and moments increase in proportion to the strength of an outward driving signal force **640** and are greatest when bobbin **602** is driven outward to the extreme position as shown in FIG. **49B**. Similarly, cone **616** experiences bending forces as on the in-stroke as in FIG. **49A** but in the opposite directions: inward **646'** on the outer portion of cone **616**, and outward **644'** on the inner portion of cone **616**. Rigid dust cap **620** contributes to the cone bending force direction on the inner and outer portions of cone **616**. Due to variations in the stiffness of cone **616** at various locations and variations in the thickness and possible internal defects in bobbin **602**, the effect of the various forces produce differences in the amount of bending of cone **616** and the upper region of bobbin **602** relative to different signal forces **650** that cause variations in the spacing of the lower portion of bobbin **602** between magnet **608** and center pole piece **610**. This results in wobble of bobbin **602** on the outstroke.

In each of FIGS. **49A** and **49B** it can be seen that when cone **616** is not in the at rest position of FIG. **47** there is a harmonic bending wave that travels through the skin of cone **616**. As can be seen in FIGS. **49A** and **49B**, the forces on cone **616** have a bending waveform illustrated by the variation in magnitude of the force vectors along the surface of cone **616** with the direction of the force vectors changing direction at some point on the surface of cone **616**. At the point where the force vectors change direction, cone **616** is bent in different directions that can be likened to bending of

a thick piece of wire. These force variations during operation of the speaker cause plastic deformation of cone **616** with the material of cone **616** having a cycles per life failure rate. The non linear stiffness in the cone, along with the offset in the spider and in the outer surround will produces a wobble that is harmonically related to the signal. This distortion is audible and is typically ignored in current speaker design. If these differences in these parts are large enough and do not cancel each other, their force will cause voice coil bobbin **602**, and perhaps also voice coil **604** to rub somewhere within the magnet assembly and eventually lead to speaker failure.

FIG. **50A** illustrates the sub-zero speaker of FIG. **48A** with bobbin **602** drawn inward to the position of the maximum stroke (similar to that of the conventional speaker of FIG. **49A**). As in the conventional speaker, in the sub-zero speaker of the present invention as bobbin **602** moves from the unexcited, at rest, position, spider **612** applies a tension on the top edge of bobbin **602** where spider **612** and cone **616** are connected to bobbin **602**. In the drawn inward position illustrated here, as in the conventional speaker of FIG. **49A**, spider force **648** has a horizontal component that is away from the center of the speaker, as well as an upward vertical component. The resiliency of surround **614** also creates an outward and upward force on the outer edge of cone **616** at the point where the outer edge of lateral support diaphragm **622** is attached. These forces create bending moments at various points in the construction of the sub-zero speaker that result in tension or compression between those points that cause a cancellation of those forces and thus maintains bobbin **602** in substantially the same alignment as when in the at rest position of FIG. **48A** as will be seen below.

To illustrate the cancellation of forces, bending moments are shown at various junction points of the components on opposite sides of the speaker. Those various points have been assigned letters that are shown in FIG. **50A** as follows:

- A left junction of the outer edge of lateral support diaphragm **622** with the point at which the outer edge of cone **616** is joined to the inner edge of surround **614**;
- B left junction of connecting ring **624** of lateral support diaphragm **622** and extension ring **628**;
- C right junction of connecting ring **624** of lateral support diaphragm **622** and extension ring **628**;
- D right junction of the outer edge of lateral support diaphragm **622** with the point at which the outer edge of cone **616** is joined to the inner edge of surround **614**;
- E left junction of inner edges of cone **616** and spider **612**, top edge of bobbin **602** and extension ring **628**; and
- F right junction of inner edges of cone **616** and spider **612**, top edge of bobbin **602** and extension ring **628**.

It can be seen that junction points A, B and E are each at a corner of a right triangle, as are junction points C, D and F. In the position of the components in FIG. **50A**, signal force **640**, spider force **648** and surround force **642** creates clock-wise bending moments at points A, B and E; and counter clock-wise bending moments at junction points C, D and F. Those bending moments thus generate compression between the following pairs of junction points: A-B, B-C and C-D; and tension between junction points A-E, B-E, C-F and D-F. Since the construction of the sub-zero speaker results in equally sized and shaped triangular areas (A-B-E and C-D-F) each with the right angle with the lateral support diaphragm **622** with the other points of each triangle pointing downward and outward, in combination with diaphragm **622** being rigid, all of the angles at the six junctions

points remain the same at each position of an inward stroke that results in bobbin 602 remaining in the same alignment as in the at rest position.

In FIG. 50B the sub-zero speaker of FIG. 48A has the voice coil bobbin 602 driven outward to the position of the extreme stroke by signal force 640 (similar to the conventional speaker of FIG. 49B). In this position, spider 612 applies a force 648 to junctions E and F. Spider force 648 has a horizontal component that is away from the center of the speaker, as well as a downward vertical component. The resiliency of surround 614 also creates a force 642 that has outward and downward components that are applied to junctions A and D.

These forces create bending moments at junction points A–F in the opposite direction to those in FIG. 50A: counter-clockwise at A, B and E, and clockwise at C, D and F. The reversal of bending moments results in the reversal of the compression and tension forces between the junction points: here tension between junction points: A–B, B–C and C–D; and compression between junction points A–E, B–E, C–F and D–F. All forces here are also balanced right to left as in FIG. 50A. Given that the construction and shapes of the components of the sub-zero speaker does not change as bobbin 602 is driven outward from that when the speaker is at rest and when bobbin 602 is drawn inward, all of the angles at the six junction points also remain the same at each position of an outward stroke that results in bobbin 602 remaining in the same alignment as in the at rest position and when drawn inward.

Thus the construction of the sub-zero speaker of the present invention provides balance between the horizontal forces on opposite sides of the top edge of bobbin 602 cancelling the forces that in the prior art speaker of FIG. 47 tend to compress the top of bobbin 602 on the in-stroke and stretch the top of bobbin 602 on the out stroke, each of which can produce wobble of bobbin 602 during operation of the speaker.

By cancelling the forces on bobbin 602 in the sub-zero speaker of the present invention, the potential for wobble of bobbin 602 during operation of the speaker is virtually eliminated.

Therefore, it can be seen that performance of the sub-zero speaker of the present invention is quite different from that of conventional speakers as has been shown by the comparison of FIGS. 50A and 50B with FIGS. 49A and 49B.

FIG. 51 is low profile version of the anti-wobble speaker of FIG. 48A. Speaker 660 of FIG. 51 includes basket 662 with magnet assembly 664 mounted centrally in the bottom of the basket with the lateral support diaphragm in position just prior to attachment to the top edge of the voice coil bobbin and the cone. In place in magnet assembly 664 is voice coil bobbin 666 and voice coil 668 in the at rest position when no signal is being applied to the voice coil. Surrounding the bobbin directly above, and preferably in contact with the top winding of, the voice coil is non-electrically and non-magnetically conductive sleeve 670. The inner diameter of sleeve 670 is substantially the same as the outer diameter of bobbin 666 with sleeve 670 glued in place. The top edge of sleeve 670 is flared outward to form a connection lip 672 that surrounds bobbin 666 with a substantial portion of bobbin 666 extending upward beyond connection lip 672. In the view of FIG. 51, voice coil 668 is wound on the lowest $\frac{3}{8}$ of the height of voice coil bobbin 666, sleeve 670 about an other $\frac{3}{8}$ of the height of the bobbin and the upper portion of the bobbin is about $\frac{1}{4}$ the height of the bobbin. These dimensions are merely an example of the portions of the different sections of the bobbin and the

present invention is not limited to those proportions. The actual proportions will be determined by the overall all design of a low-profile speaker version of the anti-wobble speaker of the present invention, as will the shape and sizes of the other components of such a speaker.

Cone 674 in this embodiment is shown having a circular center hole with the inner edge glued to connection lip 672 entirely around sleeve 670. Cone 674, radiating outward from the inner edge, rises at about 30° as shown here (not critical to the present invention) to a plateau 686 (cone connection plateau) that is flat and sloping downward at a slight angle as cone 674 radiates further from the center. The outer most portion of cone 674 is formed with a deep, downward “V” groove with the outer leg of the “V” extending outward and upward to a point that is approximately half the drop of the inner side of the “V”. It can be seen that the point at which the “V” groove begins, measuring from the center of the speaker, has a diameter that is greater than the diameter of magnet assembly 664. That being the case, when voice coil 668 is energized and is drawn inward to the maximum extent, the entire “V” groove portion of cone 674 clears magnet assembly 664 with the bottom point 682 of the “V” extending toward the bottom of basket 662 spaced apart from the outer side of magnet assembly 664.

There are two other elements, in addition to connection lip 672 that supports cone 674 and bobbin 666. One is surround 684 that has an inner edge glued to the outer most edge of cone 674 on the end of the outer leg of the “V” groove with the outer edge of surround 684 mounted on upper edge of basket 662. The other is spider 678 that has the inner edge glued to the underside of bottom point 682 of the “V” groove of cone 674 with the outer edge of spider 678 attached to basket ledge 680 inside basket 662. Basket ledge 680 is located within basket 662 at a point so that when spider 678 is in place and the speaker at rest, spider 678 is substantially level with the bottom of basket 662.

The final component of the speaker of FIG. 51 is rigid lateral support diaphragm 676 shown here just prior to attachment to cone 674 and bobbin 666. Formed in the bottom of lateral support diaphragm 676 is a connection shoulder 690 that has an inner diameter that is substantially the same as the outer diameter of bobbin 666. Around the underside of the outer edge of lateral support diaphragm 676 is a diaphragm connection flat 688 that is sized and shaped to complement the size and shape of cone connection plateau 686. To complete the assembly of the speaker illustrated in FIG. 51, lateral support diaphragm 676 is lowered on to the top edge of bobbin 666 that is glued within connection shoulder 690, and the under side of diaphragm connection flat 688 is glued to the top side of cone connection plateau 686.

Additionally, to provide free flow of air through the anti-wobble triangular region created by the upper portion of bobbin 666, the portion of diaphragm 676 between connection ring 690 and connection flat 688, and the portion of cone 674 between plateau 686 and connection lip 672, air holes can be provided below the top edge of bobbin 666 (typically done for cooling) and air holes 692 through the portion of cone 674 that provides one leg of the anti-wobble triangle. The key here to the present invention, as it is with the speaker of FIG. 48A, is the anti-wobble triangle formed around the upper edge of bobbin 666.

In the speaker of FIG. 51 the “V” groove in cone 674 radiates sound of the sound from this speaker. While not shown here, lateral support diaphragm 676 could be radiated outward and downward with the outer edge of diaphragm 676 glued to the point of connection of cone 674 and the

inner edge of surround **684**. By doing so, all of the radiated sound would be from the diaphragm. If this larger diameter diaphragm is used, air holes would be desirable through at least one leg of the “V”.

While the invention has been described with regard to several specific embodiments. Those skilled in the art will recognize that changes can be made in form and detail without departing from the spirit and scope of the invention. One skilled in the art will also find it obvious to extend the techniques discussed with respect to a passive radiator to and active speaker, and to also extend the techniques discussed relative to an active speaker to a passive radiator. This is true since a passive radiator is basically the same as a speaker without the electromagnetic engine for moving the diaphragm of the passive radiator. Thus, the protection afforded hereby is as stated in the accompanying claims and equivalents thereof.

What is claimed is:

1. A loudspeaker comprising:

a frame having an interior bottom surface with a side portion extending upward from, and surrounding, said interior bottom surface, said side portion terminating in an exterior edge of a uniform first height above said interior bottom surface with said exterior edge defining an opening into the frame having a first predetermined size and shape;

a cone having an outer edge and an inner edge, and a top surface and a bottom surface with said outer edge being substantially the same shape as, and a second size that is smaller than said first size defined by the exterior edge of the frame, with said inner edge defined by a centrally located circular hole of a first diameter through the cones, said first diameter having a third size that is smaller than said second size;

a first flexible suspension connected between the exterior edge of the frame and the outer edge of the cone;

an audio motor including a magnet assembly, having an air gap mounted to the bottom surface of the frame and a thin walled bobbin having an outer surface of a second diameter with a first end with a voice coil wound thereon and located in said air gap, and a second end with the inner edge of said cone attached to an outer surface of the bobbin at or near said second end, said first diameter and said second diameter being substantially equal one to the other; and

a stiff flat diaphragm having an outer edge, a top surface and a bottom surface; said stiff flat diaphragm having a third size that is substantially the same or smaller than said second size and is substantially the same shape as said opening defined by the exterior edge of the frame; the outer edge of the diaphragm connected to the top surface of the cone at or near said outer edge of said cone; and the bottom surface of said stiff flat diaphragm having a perpendicular connection to said second end of the bobbin;

wherein said top surface of said cone, a portion of said bottom surface of said stiff flat diaphragm and said perpendicular connection define an enclosed triangular area that encircles a center portion of said loudspeaker.

2. A loudspeaker as in claim **1**:

wherein said frame defines in said side portion an interior mounting surface therearound between said exterior edge and a top of said audio motor spaced apart from each; and

further comprising a second flexible suspension having an outer edge and an inner edge with the outer edge affixed to said interior mounting surface therearound and said

inner edge defining a center hole therein having a third diameter that is substantially equal to said first and second diameters with said inner edge attached to the outer surface of said bobbin at substantially the same location at which said inner edge of said cone is attached to said bobbin.

3. A loudspeaker as in claim **2** further comprising:

a ring shaped joining collar with an inner diameter that is substantially the same as the outer diameter of the bobbin having a top edge and an outward flaring lower edge, said joining collar affixed to said outer surface of said bobbin with said top edge of said joining collar substantially even with said second end of the bobbin and said outward flaring lower edge substantially at or near said second end of said bobbin;

wherein said inner edges of said cone and said second flexible suspension being both affixed to said outward flaring lower edge of said joining collar for attachment to said outer surface of said bobbin.

4. A loudspeaker as in claim **1** wherein said perpendicular connection includes an extension ring having a top edge and a bottom edge with said bottom edge mating with, and attached to, said second end of said bobbin and said top edge perpendicularly affixed to said bottom surface of said diaphragm above said second edge of said bobbin.

5. A loudspeaker as in claim **4** wherein said bottom edge of said extension ring is bifurcated having two tines with a space between the tines being wide enough to receive said second edge of said bobbin between the tines and to be affixed thereto.

6. A loudspeaker as in claim **4** wherein said diaphragm defines an outward extending, low height centered ring on the bottom surface sized to receive said top edge of said extension ring and be affixed thereto perpendicular to the bottom surface of the diaphragm.

7. A loudspeaker as in claim **4** wherein said diaphragm defines a centered circular positioning bead on the bottom surface disposed to mate with said top edge of said extension ring perpendicularly to said bottom surface of said diaphragm.

8. A loudspeaker as in claim **7** wherein said top edge of said extension ring defines a three tined fork with two outer tines of the same length and the center tine slightly shorter than the two outer tines to mate with said positioning bead of said diaphragm with the two outer tines spaced apart from each other to receive said positioning bead therebetween and said center tine being shorter than the two outer tines by a height of said positioning bead to facilitate the two outer tines mating with the bottom surface of said diaphragm and said center tine with a top of said positioning bead.

9. A loudspeaker as in claim **1** wherein each of said perpendicular connection and said cone define vent holes therethrough spaced therearound each of said perpendicular connection and cone to facilitate cooling of the loudspeaker.

10. A loudspeaker comprising:

a frame having an interior bottom surface with a side portion extending upward from, and surrounding, said interior bottom surface, said side portion terminating in an exterior edge of a uniform first height above said interior bottom surface with said exterior edge defining an opening into the frame having a first predetermined size and shape;

an audio motor including a magnet assembly having an air gap mounted to the bottom surface of the frame and a thin walled bobbin having an outer surface of a first diameter with a first end with a voice coil wound

35

thereon and located in said air gap, and a second end extending out of said air gap;
 a cone having an outer edge and an inner edge, and a top surface and a bottom surface with said outer edge being substantially the same shape as, and a second size that is smaller than said first size defined by the exterior edge of the frame, with said inner edge defined by a centrally located circular hole of a second diameter through the cone, said second diameter having a third size that is smaller than said second size, said inner edge of the cone is affixed to said outer surface of said bobbin spaced apart from said second end; the cone from the inner edge radiates outward and upward at a first selected angle to a flat plateau, from said plateau downward into a deep groove with an outer side of said groove extending outward and upward to said outer edge; wherein outer most ends of said plateau define a circle of a third diameter that is larger than an outer most extent of said audio motor relative to said interior bottom surface of said frame with a bottom most point of said groove defining a circle of a fourth diameter that is larger than said third diameter;
 a first flexible suspension connected between the exterior edge of the frame and the outer edge of the cone; and a stiff diaphragm having an outer edge, a top surface and a bottom surface; said stiff diaphragm having a fifth diameter that is equal to, or somewhat greater than said third diameter, the bottom surface of an outer portion of said diaphragm is affixed to said plateau of the cone, and the bottom surface of a center portion of said diaphragm is affixed to said second end of the bobbin; wherein an inner most portion of said cone, a portion of said bottom surface of said diaphragm and a portion of said outer surface of said bobbin nearest said second end define an enclosed substantially triangular area that encircles a center portion of said loudspeaker; and

36

wherein when audio motor is energized and said voice coil drawn inward the groove portion of said cone moves inward toward said bottom of said frame and clears the outer most extend of said audio motor.

11. A loudspeaker as in claim 10:

wherein said frame defines an interior mounting surface therearound spaced apart from said exterior edge and adjacent a bottom portion of said deep groove when said audio motor is unenergized; and

further comprising a second flexible suspension having an outer edge and an inner edge with the outer edge affixed to said interior mounting surface therearound and said inner edge to said bottom portion of said deep groove.

12. A loudspeaker as in claim 11 further comprising:

a ring shaped sleeve with an inner diameter that is substantially the same as the outer diameter of the bobbin having a lower edge and an outward flaring top edge, said sleeve affixed to said outer surface of said bobbin with said top edge spaced apart from said second end;

wherein said inner edge of said cone being affixed to said outward flaring top edge of said sleeve for attachment to said outer surface of said bobbin.

13. A loudspeaker as in claim 10 wherein said diaphragm includes a centrally defined circularly shape connection shoulder having a sixth diameter that is substantially equal to said first diameter, said connection shoulder affixed to said second end of said bobbin.

14. A loudspeaker as in claim 10 wherein vent holes are defined by, trough, and spaced around each of said bobbin near said second edge and a portion of said cone nearest said bobbin to facilitate cooling of the loudspeaker.

* * * * *